

WEST SOUND UTILITY DISTRICT

Board of Commissioners
Regular Board Meeting

June 7, 2023
1:00 PM

Please direct your smart device or computer to www.wsud.us/meetings for information on virtual attendance.

AGENDA

PUBLIC COMMENTS

CONSENT AGENDA

1. Approval of the Regular Board Meeting Minutes of May 17, 2023
2. Approval of Vouchers WSUD #31415 through #31458 in the amount of \$354,125.70
3. Approval of Vouchers SKWRF #17475 through #17500 in the amount of \$86,275.54

BOARD DISCUSSION/ACTION ITEM

1. Resolution 1084-23, Contract Award, Brixx Development, LLC.
2. Resolution 1085-23, Contract Award, Well 22 Project, Holt Services, Inc.
3. Resolution 1086-23, Professional Services Agreement, BHC Consultants
4. Resolution 1087-23, DEC Acceptance, Four Seasons Plat and Utility Extensions
5. Resolution 1088-23, DEC Acceptance, Payseno Lane Phase II

STAFF REPORTS

1. Plant Manager
2. Operations Manager
3. Finance Manager
4. General Manager

COMMISSIONERS' REPORTS

EXECUTIVE SESSION

Executive Sessions may be scheduled or announced for discussions per RCW 42.30.110.

FUTURE MEETINGS

June 21	Sewer Advisory Committee (City Hall)
June 21	Regular Board Meeting
July 5	Regular Board Meeting
July 21	Regular Board Meeting

Executive Sessions may be scheduled as needed for personnel, legal and other similar matters.

The Board may add and take action on other items not listed on the agenda

WEST SOUND UTILITY DISTRICT
Minutes of Meeting of the Board of Commissioners
2924 SE Lund Avenue, Port Orchard, WA 98366
Wednesday, May 17, 2023, at 1:00 p.m.

Chairperson: Susan Way (Virtual)
Vice Chairperson: James J. Hart
Commissioner: Jerry Lundberg

Attending: Randy Screws, General Manager
John Tapia, Operation Manager
Marty Grabill, Plant Manager
Joy Ramsdell, Finance Manager
Ken Bagwell, Attorney
Michaela Horishige, Accounting/Office Assistant

The meeting was called to order by Commissioner Hart at 1:00 p.m.

PUBLIC COMMENTS

CONSENT AGENDA

1. Approval of the Regular Board Meeting Minutes of May 3, 2023
2. Approval of Vouchers WSUD #31375 through #31414 in the amount of \$104,618.88
3. Approval of Vouchers SKWRF #17458 through #17474 in the amount of \$64,092.83
4. May Payroll in the Amount of \$208,994.39

Commissioner Hart moved to approve the items in the Consent Agenda. The motion was seconded by Commissioner Way; the motion was approved 3-0.

BOARD DISCUSSION/ACTION ITEM

Second Reading, Resolution 1078-23, Retrospective Rating Agreement
Passed, 2 yeas, 1 abstention.

Resolution 1081-23, Amending Title 3 of the Administrative Code
Passed 3-0

Resolution 1082-23, Amending Title 9 of the Administrative Code
Passed, 2 yeas, 1 abstention.

Resolution 1083-23, Change in Position, WSUD Employee
Passed 3-0

STAFF REPORTS

PLANT MANAGER'S REPORT

Plant Manager Marty Grabill reported:

- Testing and monitoring as required by the NPDES Permits.
- Primary skimmers are on order; delivery is scheduled for the end of May. These are to be installed by SKWRF staff.
- Generator load bank replacement- Awaiting signatures from Legacy Power Systems.
- MBR Blower replacement order placed. Delivery is set for July.
- Currently looking at different preventative maintenance software for the treatment plant with demos from Cartegraph, Lumin, and Novotx.
- Still working on getting accredited for in-house nutrient testing.
- Second quarter stormwater testing completed.
- Reaching out for quotes on asphalt modifications to remove storm drains and sampling requirements. One site visit is scheduled for Thursday, May 18th.

PSE Conservation Grant Agreement (2021-2023)

- Continuous work with PSE on Conservation Grant Agreement. Year 3 of 3.
- Currently working on grant funding potential for the RDT.

Rotary Drum Thickener-ESCO (2022)

- Job shack was delivered May 8th.
- Mobilization began on May 15th. Currently working on structural improvements, followed by concrete work and then installation.
- Closeout is set for July 1st, with full completion by the end of August.

OPERATION MANAGER'S REPORT

Operations Manager John Tapia reported:

CIP - South Park Main Replacement

- Locate and survey completed for the site.
- WSE is working on the recommended easement.

Powell Booster Station Engineering

- 100% Plans are completed.

Fircrest/Mile Hill Main Replacement

- 2" galvanized to be replaced.
- Possible development going in.

Olney Sewer Replacement

- Engineering contract has been signed with WSE.

- Project design has started with locate being complete.
- Going through project options with WSE.

Crew

1. St. Vincent DePaul project: City contacted about the permit. Reached out to Caseco for time update. Not enough workers lately.
2. Commercial water meter replacements continue. Five left, all retirement homes.
3. Residential water meter replacements continue.
4. As meters are replaced, we are doing service line inventory that is entered into Vue Works.
5. Vac-con ordered; ETA is at the end of June.
6. The TV van was received on Monday!
7. New pumps installed in Villa Carmel. The second pump VFD IOS card went out and is waiting on a replacement.
8. Catching up on flush/TV work orders.
9. WSDOT Franchise permit is moving forward.
10. Spring cleaning sites and facility continues.
11. Tank cleaning will be done around October.

Water Production Through April

- 2022: 161,349,000 gal.
- 2023: 151,990,000 gal.
- 1.27 million per day avg.
- Difference: 9,359,000 gal. less

Rain Gauge

- 2022: 24.15"
- 2023: 18.07"
- Difference: 6.08" LESS than last year

FINANCE MANAGER'S REPORT

Finance Manager Joy Ramsdell reported:

- As of yesterday, there are 167 past due accounts with balances totaling \$43K. We sent 103 final letters and only shut off 6 accounts today.
- The new escrow utility estimation is working well. 39 estimations given out this month.
- Notice from ESD regarding WA Cares long term care insurance program, premiums will be withheld starting July 1st. There is no employer share and previously approved exemptions are still valid. The deduction rate is 0.58% with no cap on income.
- The Plant's annual report was filed. WSUD's draft is done, and GM Randy Screws is reviewing it, should be filed by the end of the month.

GENERAL MANAGER'S REPORT

General Manager Randy Screws reported:

- Staff is currently assessing installation scenarios for the proposed carport-type area for District vehicles currently in the open.
- Staff continue working on the re-establishment of a franchise agreement with WSDOT for water utilities.
- The Well 22 bid opening occurred on Monday, May 15th at 2:00 p.m. The District received three bids. The lowest responsible bidder provided a bid in the amount of \$246,500.00 for the Well 22 work of rehabilitation, supply of new pump and motor and extending the column down approximately 150'. There is a budget amount of 245K for the line item. Water Capital fund has sufficient funding for the project.
- Estimated cost for the Powell Booster Station came in higher than expected. We will continue to assess and plan for this project. This would be a good candidate for a Public Works Board (PWB) Loan.
- Water system plan: We have been pushing for the approval of the plan. The District has been notified by DOH that they are nearing the issuance of an approval letter. We continue to consider and address comments from adjacent purveyors.
- Preparing for the PWB application process for the water utility.
- Continuing to work on the viability of gravity sewer from the Annapolis lift station to eliminate the overflow connection to the City's sewer system.
- An Executive Session is requested for the purpose of considering the performance of a public employee under RCW 42.30.110 section 1(g). I request a five-minute Executive Session. I anticipate action to be taken following the Executive Session.

COMMISSIONERS' REPORTS

Nothing to report.

EXECUTIVE SESSION

The Board entered a 5-minute Executive Session with GM Randy Screws and Operations Manager John Tapia at 2:40 p.m. Executive Session ended at 2:45 p.m. with action taken.

ADJOURN

Commissioner Hart moved to adjourn the meeting at 2:45 p.m. Motion was seconded by Commissioner Lundberg; the motion was approved 3-0.

Susan Way
Chairperson

James Jay Hart
Vice-Chairperson

Jerry Lundberg
Secretary

**WEST SOUND UTILITY DISTRICT
RESOLUTION 1084-23**

**A RESOLUTION OF THE BOARD OF COMMISSIONERS
OF WEST SOUND UTILITY DISTRICT
APPROVING A SEWER MAIN EXTENSION
AS A SOLE SOURCE CONTRACT
ON KITSAP COUNTY
TAX PARCEL 4598-005-017-0307**

WHEREAS, Mr. Brett McDonough, Manager of Brixx Development, LLC., had previously submitted an application, plans and documents for the extension of water and sewer services for Phase II of the Multifamily Development, Overlook Apartments on Kitsap County Tax Parcel # 4598-005-017-0307 and a Developers Extension Contract was approved by Resolution 997-22 on February 22, 2022; and

WHEREAS, it shall be the responsibility of the developer to construct the water and sewer system to and within their development site in accordance with the standards of West Sound Utility District and as approved by the District; and

WHEREAS, the District has determined that in addition to the approved infrastructure, additional infrastructure consisting of a sewer main extension on the subject property to the public Right of Way, west to Orlando Street would be beneficial to the District for future sanitary sewer connections in the sub area basin; and

WHEREAS, it has been identified by staff that extension of the sanitary sewer infrastructure after completion of the site development would be considered complicated and costly due to final site conditions once land development activities are completed and as such, the District considers this work an emergent need during site development; and

WHEREAS, the Developer has agreed to allow for the sewer main extension work and easement on the property and provide for the work to be completed from the onsite contractor DRK Development, Inc. who has provided an estimate of cost (Exhibit "A") for the installation of additional sewer infrastructure requested by the District; and

WHEREAS, the emergent need of such work, with consideration of current market conditions, costs for future work due to site conditions once the land development is complete, and by having the current on-site development contractor complete the work, saves the District significant cost, time and is in the best interest of its ratepayers; **NOW, THEREFORE**,

THE BOARD OF COMMISSIONERS OF WEST SOUND UTILITY DISTRICT HEREBY RESOLVES:

Section 1. The Board approves exemption from competitive bidding requirements under RCW 39.04.280 as a sole source contract due to market conditions and special facilities.

Section 2. West Sound Utility District Board of Commissioners hereby approves the execution of a Small Works Contract (Exhibit “B”) with Mr. Brett McDonough, Manager of Brixx Development, LLC., for the extension and easement for three-hundred seventy-eight (378) feet of 8” sewer main and two manholes of an average depth of 18.30’ below finished grade to terminate within the public Right of Way on Orlando Street in the amount of \$91,870.00 plus applicable tax in the amount of \$8,543.91; and to approve amendments to the Contract or change orders in an amount not to exceed 10% of the Contract amount provided the changes are: a) within the scope of the project, b) consistent with the bid process; and c) executed in writing.

APPROVED and ADOPTED by the Board of Commissioners of West Sound Utility District at a regularly scheduled Board meeting on June 7, 2023.

WEST SOUND UTILITY DISTRICT
Kitsap County, Washington

Susan Way
Chairperson

James J. Hart
Vice Chairperson

Jerry Lundberg
Secretary

TO: WSUD C/O Randy Screws
FROM: Bryan Walters, DRK Development, Inc.
Re: Overlook Sewer Main Extension Cost

Mobilization In/Out	\$ 1,800.00
Additional Shoring	\$ 1,500.00
Connect to Ex 17.63 Deep, Core and Re-channel	\$ 11,950.00
2 - 48" SSMH 22.44 Deep, 18.30 Deep	\$ 17,900.00
378' 8" PVC Sewer pipe/fittings	\$ 51,150.00
Test & Flush Pipe, Vac Test Manholes	\$ <u>7,570.00</u>
SubTotal	\$ 91,870.00
Tax (9.3%)	\$ <u>8,543.91</u>
Total	\$100,413.91



Signature

5-17-23

Date

SMALL WORKS CONTRACT

Parties: WEST SOUND UTILITY DISTRICT &

THIS IS AN AGREEMENT entered into between West Sound Utility District, a Washington State Municipal Corporation, hereinafter called "District," and _____, hereinafter called "Contractor."

Pursuant to its resolutions and procedures, the District has determined the Contractor to be the lowest responsible bidder to perform the services hereinafter described. The purpose of this document is to set forth the specific terms of the parties' agreement in writing.

NOW, THEREFORE, in consideration of the foregoing recitals and the promises and covenants of the parties hereinafter set forth, they agree as follows:

1. Services to be performed by Contractor. The services to be performed are identified in the attached plans and specifications, referred to as Attachment "A" which by this reference is incorporated herein. In performing its work, the Contractor shall supply all necessary labor and materials to fully and completely finish the work called for herein.

2. Payment for Services. The total payment from the District to the Contractor for the work to be performed by the Contractor as described herein shall be **the total sum of \$ _____ plus applicable Washington State sales tax.** Payment of this said amount shall be due and owing within forty-five days of the completion of the work by the Contractor and acceptance by the District. Acceptance shall not be unreasonably withheld.

3. Commencement/Completion of Work. **The contractor shall commence its work for the District on or before _____.** **All work called for herein shall be fully completed by the Contractor on or before _____.**

4. Contractor Representations. The Contractor hereby represents and warrants to the District as follows:

A. Bonding Company and License No. The Contractor is fully licensed, bonded, and in good standing with the State of Washington.

- 1) It's Contractor License Number. with Washington State is _____
- 2) It is currently bonded with the following bonding company to do business in the State of Washington
 - a) Bond No. _____.
 - b) This bond was issued on the ____, day of _____, 20__.

3) In addition to the above, the Contractor is required to provide a Performance Bond and Payment in accordance with the Prevailing Wage regulations prior to the commencement of work.

B. Evidence of Insurance. Prior to performing its construction work, the Contractor shall provide the District with written evidence of insurance covering public liability and property damage concerning the work to be performed. If the total amount of services to be performed by the

Contractor exceeds five thousand and 00/100 dollars (\$5,000.00) the coverage limits for liability shall be not less than as set forth on Attachment "B" entitled "Minimum Requirements for Certificates of Insurance" which by this reference is incorporated herein and made a part hereof.

In the event Attachment "B" is applicable hereto, the Contractor shall be obligated to comply with all terms and specifications set forth therein.

C. Hold Harmless Provision. The Contractor shall indemnify, defend, and hold harmless the District, its engineer, agents, and employees from any and all claims, demands, actions, and/or liabilities of every kind and nature as may be made and/or entered against the Districts, its engineer, their agents, and employees by reason of, or arising out of, the acts or omissions of the Contractor, its agents, or employees, including costs and attorney's fees incurred by the Districts and its agents and representatives in investigating and defending against any such claims in the event of failure of the Contractor to so defend as herein required.

D. Prevailing Wages. Concerning the work called for herein, the Contractor agrees to pay hourly wages to its laborers and workers in accordance with Washington law and specifically in accordance with RCW 39.12.020 dealing with the prevailing rates to be paid on public-works projects. The Contractor represents it is fully knowledgeable concerning the terms of RCW 39.12.020. The first invoice cannot be paid until the District has received the approved Intent to Pay Prevailing Wages. Retainage shall be 5% of each invoice. Retainage cannot be released until the Affidavit of Wages Paid is approved by the State and the Department of Revenue has approved the release of funds.

E. Performance of Work. The Contractor shall perform all work in a good, workmanlike and timely fashion. All materials used by the Contractor in its work shall be of a good or superior quality. In performing its work, the Contractor shall also act in accordance with all applicable local, state, and federal laws and regulations.

F. Warranty. The Contractor represents and warrants that all services and materials used by it in its services for the District shall be completely free of defects for a period of time lasting two (2) years from the date of completion. In the event any defects are discovered within the warranty time concerning the Contractor's services or materials used by it, the Contractor shall promptly cure any said defects.

G. Non-assignment of Obligations. The contractor is hereby prohibited from assigning or in any manner transferring its obligations under this contract to any third party or entity. The Contractor shall be personally responsible for performance of all work and obligations placed upon it hereunder. The person in charge of the Contractor's work hereunder shall be _____, and he/she shall make him or herself available to the District representative at all reasonable time for consultation.

H. District Inspection. Prior to commencing its work, the Contractor shall meet with the District representative(s) and these parties shall set forth an inspection schedule to be followed by the District in inspecting the Contractor's work while it is in progress. The contractor shall promptly report to the District, in writing, all errors and omissions it commits in performing the work.

5. Risk of Loss. Until the Contractor's work for the District has been fully completed and accepted by the District, all risk of loss concerning the project shall be borne by the Contractor.

6. Cooperation of Parties. The parties shall strive at all times to cooperate with one another in good faith so the terms and spirit of this agreement may be carried out in a good and timely manner.

7. Legal Action. In the event either party employs an attorney to enforce or defend any claim or cause of action arising out of or relating to this agreement, or any appeal therefrom, then and in

any such event, the prevailing party shall be entitled to recover from the losing party, and the losing party shall pay, all of the prevailing parties reasonable costs and attorney fees therein incurred. The venue and jurisdiction for any such action shall lie with the appropriate court in Kitsap County, Washington.

8. Complete Agreement. This agreement constitutes the full and complete agreement between the parties concerning the matters set forth herein. There are no other agreements, either written or verbal, in existence.

DATED this _____ day of _____, 20_____.

WEST SOUND UTILITY DISTRICT:

Glen R. Screws, General Manager

CONTRACTOR:

ATTACHMENT "B"
MINIMUM REQUIREMENTS FOR
CERTIFICATES OF INSURANCE

COMMERCIAL GENERAL LIABILITY

Bodily Injury	\$500,000 each person \$2,000,000 each occurrence
Property Damage	\$2,000,000 each occurrence \$4,000,000 gen. aggregate
or	
Combined Single Limit	\$2,000,000 each occurrence \$4,000,000 gen. aggregate
Employers Liability	\$2,000,000 each accident \$1,000,000 each employee - disease \$1,000,000 policy limit - disease

AUTOMOBILE LIABILITY

Bodily Injury	\$500,000 each person \$2,000,000 each occurrence
Property Damage	\$2,000,000 each occurrence
or	
Combined Single Limit	\$2,000,000 each occurrence

WORKERS COMPENSATION

Limits	Statutory (show L & I ID #)
--------	--------------------------------

Certificates shall be issued through insurance companies licensed to do business in the State of Washington pursuant to Title 48 RCW and who have a "Best's Insurance Guide" rating of not less than A+VII

Certificates of Insurance must be on file with the Districts prior to the start of any operations within the District.

Public Liability and Property Damage Insurance

General Requirements

1.1 The Contractor shall obtain and keep in force during the term of the contract, Commercial General Liability and Automobile liability insurance policies with insurance companies which have an A.M. Best's rating of A-: VII or better and who are approved by the Insurance Commissioner of the State of Washington pursuant to Title 48 RCW. All insurance coverage required by these specifications shall be written and provided by "occurrence-based" policy forms rather than "claims made" forms.

1.2 Prior to the execution of the contract, the Contractor shall purchase and maintain during the term of this project a Commercial General Liability insurance and Automobile insurance policies meeting the requirements set forth herein. The Contractor shall file with the District **either** a certified copy of all policies **with endorsements attached**, or a certificate of insurance **with endorsements attached** as are necessary to comply with these specifications. Failure of the Contractor to fully comply with the requirements regarding insurance will be considered a material breach of contract and shall be cause for immediate termination of the contract and of any and all District obligations, regarding same.

1.3 The Contractor shall not begin work under the contract or under any special condition until all required insurances have been obtained and until such insurances have been approved by the District. The insurance shall provide coverage for the Contractor, the Contractor's agents and employees, subcontractors, and the District. The coverage so provided shall protect against claims from bodily injuries, including accidental death, as well as claims for property damage which may arise from any act or omission of the Contractor, the Contractor's agents and employees, subcontractors, or by anyone directly or indirectly employed by either of them.

1.4 The insurance policies shall specifically name the District, its elected and appointed officials, officers, employees, agents and volunteers as additional insureds with regards to damages and defense of claims arising from: (a) activities performed by or on behalf of the Contractor; (b) products and completed operations of the Contractor, and (c) premises owned, leased or used by the Contractor. The insurance shall be maintained in full force and effect at the Contractor's expense throughout the term of the contract. Products and completed operations coverage shall be maintained for a minimum of three years after completion of the project.

1.5 The District shall be given at least 45 days written notice of any cancellation, nonrenewal, material reduction, or modification of coverage. Such notice shall be by *certified mail* to the District.

1.6 The coverages provided by the Contractor's insurance policies shall be primary to any insurance maintained by the District, except as respects losses attributable to the sole negligence of the District or otherwise limited in accord with the provisions of RCW 4.24.115. Any insurance that might cover this contract that is maintained by the District shall be in excess of the Contractor's insurance and shall not contribute with the Contractor's insurance.

1.7 The Contractor's insurance policies shall protect each insured in the same manner as though a separate policy had been issued to each. The inclusion of more than one insured shall not affect the rights of any insured as respects any claim, suit or judgment made or brought by or for any other insured or by or for any employee of any other insured. However this provision shall not increase the limits of the insurer's liability.

1.8 The General Aggregate provision of the Contractor's insurance policies shall be amended by endorsement to show that the General Aggregate Limit of the policies applies separately to this project.

1.9 The Contractor's insurance policies shall not contain deductibles or self-insured retentions in excess of \$10,000 unless approved by the District.

1.10 The Contractor's insurance policies shall contain a provision that the District has no obligation to report events which might give rise to a claim until a claim has been filed with the District's Board of Commissioners.

1.11 Types and Limits of Insurance Required:

Commercial General Liability

- \$2,000,000 each occurrence Bodily Injury and Property Damage liability
- \$2,000,000 annual aggregate
- Employees and volunteers as Additional Insureds
- Premises and operations
- Broad form property damage including underground, explosion and collapse hazards (XCU)
- Products completed operations (shall be maintained for at least three years after completion.)
- Blanket contractual
- Subcontractors
- Personal injury with employee exclusion deleted
- Employers liability (Stop gap)

Automobile Liability

- \$2,000,000 per accident bodily injury and property damage liability, including
- Any owned automobile
- Hired automobiles
- Non-owned automobile

Umbrella Liability (applicable to both the Commercial General and Auto Liability coverage and employers liability, provided this requirement may be satisfied through the Contractor's primary commercial general and auto liability coverage, or any combination thereof.

- \$2,000,000 per occurrence
- \$2,000,000 aggregate

1.12 Providing coverages in the stated amounts shall not be construed to relieve the Contractor from liability in excess of such limits.

1.13 The Contractor shall have its insurance agent/representative complete the Insurance Coverage Questionnaire contained in the proposal and attach it to the certificate of insurance for District's approval.

1.14 The Contractor shall maintain Workers Compensation insurance and/or Longshore and Harbor Workers insurance (or Jones Act coverage for all employees eligible for same) as required by state or federal statute for all of the Contractor's employees to be engaged in work on the project under this contract and, in case any such work is sublet, the Contractor shall require the subcontractor similarly to provide workers compensation insurance and/or longshore and harbor workers insurance (or Jones Act coverage) for all of the subcontractor's employees to be engaged in such work. The Contractor's Department of Labor & Industries account number shall be noted on the certificate of insurance. In the event any class of employees engaged in the work under this contract is not covered under Workers Compensation insurance or Longshore and Harbor Workers insurance (or Jones Act coverage) as required by state and federal statute, the Contractor shall maintain and cause each subcontractor to maintain, Employers Liability insurance for limits of at least \$1,000,000 for each employee for disease or accident, and shall furnish the District with satisfactory evidence of such.

1.15 The Contractor shall be solely and completely responsible for safety and safety conditions on the job site, including the safety of all persons and property during performance of the work. The services of District employees or the engineer's personnel in conducting construction review of the Contractor's performance is not intended to include review of the adequacy of the Contractor's work methods, equipment, bracing, scaffolding, or trenching, or safety measures in, on, or near the construction site. The Contractor shall provide safe access for the District and its inspectors to adequately inspect the quality of work and the conformance with project specifications.

1.16 The Contractor shall be solely and completely responsible to perform all work and furnish all materials in strict compliance with all applicable state, city, county and federal laws, regulations, ordinances, orders and codes. The Contractor's attention is directed to the requirements of the Washington Industrial Safety and Health Act (WISHA), Chapter 49.17 RCW.

1.17 The District will make no progress payments until the Contractor has fully complied with this section. This remedy is not exclusive and the District may take such other action as is available under other provisions of this contract, or otherwise in law.

1.18 The contractual coverage of the Contractor's policy shall be sufficiently broad enough to insure the provisions of the **HOLD HARMLESS AND INDEMNIFICATION AGREEMENT** of this contract.

1.19 Nothing contained in these insurance requirements shall be construed as limiting the extent of the Contractor's responsibility for payment of damages resulting from the Contractor's operations under this contract.

SUBCONTRACTORS

The Contractor shall ensure that each subcontractor of every tier obtains and maintains at a minimum the insurance coverages listed above. Upon request of the District, the Contractor shall provide evidence of such insurance.

EVIDENCE OF INSURANCE

The Contractor shall provide to the District a certificate(s) of insurance and endorsements for each policy of insurance meeting the requirements set forth herein when the Contractor delivers the signed contract to the District for the work. The certificate and endorsements shall conform to the following requirements:

1. An Acord certificate or a form determined by the District to be equivalent. The certificate or an endorsement form shall indicate the Contractor's insurance is primary and non-contributory.
2. The Contractor shall obtain endorsement forms CG 20 10 10 01 and CG 20 37 10 01, or the equivalent of each, naming the District and all other parties listed herein as Additional Insured(s) and providing the policy number. If the Contractor is unsuccessful in securing these endorsements after exerting commercially reasonable efforts, the Contractor shall obtain other endorsements providing equivalent coverage to the Additional Insured, subject to the review and approval of such other endorsement forms by the District. A statement of additional insured status on an Acord certificate of insurance shall not satisfy this requirement. Commercially reasonable efforts shall be evidenced by a signed statement by the Contractor's insurance broker certifying the endorsement forms required by the District are not available and the endorsements submitted provide equivalent coverage to the Additional Insured.
3. Any other amendatory endorsements to show the coverage required herein.

NOTE: THIS QUESTIONNAIRE MUST BE COMPLETED AND ATTACHED TO CERTIFICATE OF INSURANCE AND POLICY ENDORSEMENT.

Insurance Coverage Questionnaire

For _____
(Name of Insured)

Project Number _____

Project Owner _____

Are the following coverages &/or conditions in effect?		
	Yes	No
The Policy form is ISO Commercial General Liability (CGL) form CG 00 01 of CG 00 02 (circle one). If No, attach a copy of the policy with required coverages clearly identified.		
(CGL) Ongoing Operations coverage (similar to CG 20 10 10 01, CG 2010 07 04, or equivalent)		
(CGL) Products and Completed operations coverage (similar to CG 20 37 07 04, CG 20 37 07 04, or equivalent)		
Personal Injury Liability Coverage. (with employee exclusion deleted)		
Broad Form Property Damage with X, C, U Hazards included		
Blanket Contractual Liability coverage applying to this contract		
Employers Liability - Stop Gap		

Deductibles or SIRs: GL _____ AL _____ Excess _____

Insurer' Best Rating GL _____ AL _____ Excess _____

This Questionnaire is issued as a matter of information. This questionnaire is not an insurance policy and does not amend, extend or alter the coverage afforded by the policies indicated on the attached Certificate of Insurance.

Agency/Broker

Completed by (type)

Address

Completed by (Signature)

Name of Person to contact

Telephone Number

PERFORMANCE AND PAYMENT BOND

KNOW ALL MEN BY THESE PRESENTS: THAT whereas West Sound Utility District, Port Orchard, Washington a municipal corporation has awarded to:

(Contractor)

hereinafter designated as the "Principal", a contract for work items, which contract consists of the Proposal/Agreement, together with the Contract Documents, Specifications, Addenda and Plans, all as hereto attached and made a part hereof, and more particularly described as:

and whereas said principal is required under the terms of said contract to furnish a bond for the faithful performance of said contract:

NOW, THEREFORE, we the Principal and _____, a corporation, organized and existing under and by virtue of the laws of the State of Washington, and duly authorized to do business in the State of Washington as surety, are firmly bound unto West Sound Utility District in the sum of _____ lawful money of the United States, for the payment of which sum well and truly to be made, we bind ourselves, our heirs, executors, administrators, successors and assigns, jointly and severally, firmly by these presents.

THE CONDITION OF THIS OBLIGATION IS SUCH, that if the above bonded principal, his or its heirs, executors, administrators, successors or assigns, shall in all things stand to and abide by, and well and truly keep and perform the covenants, conditions and agreements in said contract, and shall faithfully perform all the provisions of such contract, and shall also well and truly perform and fulfill all the undertakings, covenants, terms, conditions and agreements of any and all duly authorized modifications of said contract that may hereafter be made, at the time and in the manner therein specified; and shall pay all laborers, mechanics, subcontractors and materialmen, and all persons who shall supply such person or persons, or subcontractors, with provisions and supplies for the carrying on of such work on his or their parts; and shall indemnify and save harmless the Owner's Engineer, its officers and agents, from any loss or damage occasioned to any person or property by reason of any careless or negligence on the part of said principal, or any subcontractor, in the performance of said contract or any modifications thereof; and shall further indemnify and save harmless West Sound Utility District, its officers and agents, from any damage or expense by reason of failure of performance as required by said contract, or any modifications thereof, or from defects appearing or developing in the material or workmanship provided or performed under said contract within a period of two years after acceptance thereof by West Sound Utility District, then this obligation shall become null and void, otherwise it shall be and remain in full force and effect.

And the said surety, for value received, hereby further stipulates and agrees that no change, extension of time, alteration or addition to the terms of the contract or to the work to be performed thereunder or the specifications accompanying the same shall in any way affect its obligation on this bond, and it does hereby waive notice of any change, extension of time, alternations or additions to the terms of the contract or the work or to the specifications.

IN WITNESS THEREOF, the said Principal and the said surety caused this bond and three (3) counterparts thereof to be signed and sealed by their duly authorized officers, this _____ day of _____, 20__.

Principal

By _____

Title _____

ATTEST (If Corporation)

WITNESSES (If Individual or Partnership)

CORPORATE SEAL

By _____

Title _____

Address of local office and agent of Surety Company is:

NON-COLLUSION AFFIDAVIT
(Contractor/Proposer)

State of Washington)
) ss
County of Kitsap)

The undersigned, being duly sworn, deposes and says that the person, firm, association, co-partnership or corporation herein named, has not, either directly or indirectly, entered into any agreement, participated in any collusion, or otherwise taken any action in restraint of free competitive bidding in the preparation and submission of a proposal to WSUD for consideration in the award of a Contract on the Project described as follows: _____
_____.

Name of Firm (Contractor)

Authorized Signature

Title
(Affix Corporate Seal)

STATE OF WASHINGTON)
) ss
COUNTY OF KITSAP)

I certify that I know or have satisfactory evidence that _____, is the person who appeared before me, and said person acknowledged he signed this instrument, and on oath stated he was authorized to execute it on behalf of _____, a Washington _____; and he acknowledged it as the authorized signer of said _____, to be the free and voluntary act of such _____ for the uses and purposes mentioned in the instrument.

Dated: _____

Print Name: _____
NOTARY PUBLIC in and for the State of
Washington, residing in _____

My Commission Expires: _____

**NON-COLLUSION AFFIDAVIT
(Subcontractor)**

State of Washington)
) ss
County of Kitsap)

The undersigned, being duly sworn, deposes and says that the person, firm, association, co-partnership or corporation herein named, has not, either directly or indirectly, entered into any agreement, participated in any collusion, or otherwise taken any action in restraint of free competitive bidding in the preparation and submission of a proposal to subcontract work in connection with the Project as specified in the proposal submitted by

_____.

Name of Firm (Subcontractor)

Authorized Signature

Title
(Affix Corporate Seal)

STATE OF WASHINGTON)
) ss
COUNTY OF KITSAP)

I certify that I know or have satisfactory evidence that _____, is the person who appeared before me, and said person acknowledged he signed this instrument, and on oath stated he was authorized to execute it on behalf of _____, a Washington _____; and he acknowledged it as the authorized signer of said _____, to be the free and voluntary act of such _____ for the uses and purposes mentioned in the instrument.

Dated: _____

Print Name: _____
NOTARY PUBLIC in and for the State of
Washington, residing in _____

My Commission Expires: _____

**WEST SOUND UTILITY DISTRICT
BID BOND FORM**

Herewith find deposit in the form of a certified check, cashier's check, or cash in the amount of \$ _____ which is **not less than five percent (5%) of the total bid.**

Sign Here: _____

BID BOND

Know all men by these presents, that we _____ as Principal and _____ as Surety, are held and firmly bound unto WSUD, as obligee in the penal sum of _____ dollars, for the payment of which the principal and the surety binds themselves, their heirs, executors, administrators, successors and assigns, jointly and severally, by these presents.

The condition of the obligation is such that if the obligee shall make any award to the principal for _____, according to the terms of the proposal or bid made by the principal therefore, and the principal shall duly make and enter into a contract with the obligee in accordance with the terms of said proposal or bid award and shall give bond for faithful performance thereof, with surety or sureties approved by the obligee; or if the principal shall, in case of failure to do so, pay and forfeit to the obligee the penal amount of the deposit specified in the call for bids, then this obligation shall be null and void; otherwise it shall be and remain in full force and effect and the surety shall forthwith pay and forfeit to the obligee, as penalty and liquidated damages the amount of this bond.

Signed, sealed, and dated this _____ day of _____, 20_____.

Principal: _____

Surety: _____

Return of deposit in the amount of
\$ _____

Date: _____ By: _____

**WEST SOUND UTILITY DISTRICT
RESOLUTION 1085-23**

**A RESOLUTION OF THE
WEST SOUND UTILITY DISTRICT BOARD OF COMMISSIONERS
AUTHORIZING CONTRACT AWARD FOR THE
WELL 22 REHABILITATION, PUMP, MOTOR REPLACEMENT, AND
COLUMN EXTENSION PROJECT WITH HOLT SERVICES, INC.**

WHEREAS, the District’s Well 22 requires rehabilitation services for a new pump, motor, and extension of its well column; and

WHEREAS, the Water Capital Fund contains funding for such work; and

WHEREAS, utilizing the formal competitive bidding procurement process, the District prepared and advertised plans, and specifications for the project (Exhibit “A”); and

WHEREAS, the District received three (3) bids from contractors with the ability to perform the requested work from the small works roster with a bid opening that occurred on May 15, 2023, at 2:00 pm; and

WHEREAS, of the bids received, the lowest responsible bidder for the project was Holt Services, Inc. who provided a bid in the amount of \$246,500.00 not including applicable tax; **NOW, THEREFORE**,

THE BOARD OF COMMISSIONERS OF WEST SOUND UTILITY DISTRICT HEREBY RESOLVES:

Section 1. The Board approves and awards the small works contract for the Well 22 well rehabilitation, pump, motor replacement, and column extension project to Holt Services, Inc. in the amount of \$246,500.00, plus applicable taxes.

Section 2. The General Manager is hereby authorized to execute the small works contract (Exhibit “B”) with Holt Services, Inc. and is further authorized to approve amendments to the Contract or change orders in an amount not to exceed 5% of the Contract amount, provided the changes are: a) within the scope of the project; b) consistent with the bid process; and c) executed in writing.

APPROVED and ADOPTED by the Board of Commissioners of West Sound Utility District at a Board meeting scheduled June 7, 2023.

WEST SOUND UTILITY DISTRICT
Kitsap County, Washington

Susan Way
Chairperson

James J. Hart
Vice Chairperson

Jerry Lundberg
Secretary

2023



Well 22 Rehabilitation, Pump, Motor Replacement and Column Extension

WELL 22 PUMP REPLACEMENT AND REHABILITATION

TABLE OF CONTENTS

Notice to Bidders	2
Instruction to Bidders	3
District Public Works Contract (Sample)	4
Performance and Payment Bond (Sample)	7
Bid Bond Form (Required for Bid Submission)	9
Insurance Requirements	10
General Information	16
Scope of Work	17
Equipment and Materials	17
Execution of Work	17
Submittals	19
Measurement and Payment	19
Bid Proposal Sheet (Required for Bid Submission)	20
General Provisions	21
Special Specifications	25
Prevailing Wage Procedures	25
Well Construction Details	26
Current Well Configuration	27
Supply Pump and Motor Reference Information	28

SECTION I

NOTICE TO BIDDERS

West Sound Utility District is seeking a qualified contractor to provide a pump, motor replacement, and rehabilitation services and to extend the pump column length an additional 150' for its Well 22.

Well 22 is a 16-inch diameter well located at 2823 SE Lund Avenue in Port Orchard, Washington 98366. The well was drilled in 2010 to a depth of 1,525 feet with 16-inch casing and is completed with a 21-foot, 10-inch diameter tailpipe from 1,476 to 1,497 feet below ground surface (bgs) and 140 feet of 10-inch diameter, 30-slot, stainless-steel screen set from 1,336 to 1,476 feet bgs. The 10-inch diameter riser assembly extends up to 1,262 feet bgs and includes an unexposed, 30-slot pressure-relief screen from 1,306 to 1,315 feet bgs. The screen is packed with a filter pack of 10-20 Colorado Silica sand.

Sealed bids will be received by West Sound Utility District ("District") until 2 p.m. on May 15, 2023, at the office of West Sound Utility District located at 2924 SE Lund Avenue, Port Orchard, Washington, 98366. Bids received after such time and date will not be considered. No Bidder may withdraw a Bid after the deadline for the submittal of bids. Bids properly received will be publicly opened and read at the District Offices following the deadline for the submission of bids. Bids shall be submitted in accordance with the Contract Documents. Bids shall constitute offers to the District which shall be binding for thirty (30) days from the date of bid opening.

The District reserves the right to reject any bid, any portion of any bid and/or to reject all bids. The District further reserves the right, but without obligation, to waive informalities and irregularities. **No bid will be considered unless accompanied by a bid guaranty (certified or cashier's check, surety bond, or postal money order) payable to West Sound Utility District in an amount not less than five percent (5%) of the Bid.**

Bid Documents may be obtained at the West Sound Utility District office at the address above or by downloading from the district website at www.wsud.us/rfps. The District reserves the right to award to the lowest responsive, responsible bidder as it best serves the interest of the District. The Bidder to whom the Contract is awarded shall execute and return the Contract to the District within fifteen (15) calendar days from the date the Notice of Award is mailed to the Bidder. In case of failure of the Bidder to execute the Contract, the Bidder shall be in default, the Bid Bond shall be forfeited to the District and the District shall have the right to award the Contract to the next lowest responsive, responsible Bidder.

Questions regarding Contract Documents, or this invitation to bid may be directed to John Tapia at West Sound Utility District at 360-874-5012 or jtapia@wsud.us. A bidder may be required to submit a question in writing. No oral responses to questions by District personnel about the bid will be binding on the District.

INSTRUCTIONS TO BIDDERS

FORM OF BID: Proposals shall be made upon the form(s) provided.

SUBMISSION OF BID: Bid on Proposal Form, Bid Bond and Schedule of Bid Prices shall be enclosed in an opaque sealed envelope, addressed to the named in the NOTICE TO BIDDERS, and delivered as required by the NOTICE TO BIDDERS.

EVIDENCE OF QUALIFICATIONS: Upon request of the District, a bidder whose bid is under consideration for the award of the contract shall submit promptly to the District satisfactory evidence of the bidder's financial resources, his/her experience, and the organization and equipment he has available for the performance of the contract.

REJECTION OF BIDS: The District reserves the right to reject any and/or all proposals and also the right to waive any formalities in connection with said proposals or bids.

PERFORMANCE BOND: The successful bidder will be required to furnish, prior to final award of contract and within fifteen (15) calendar days after acceptance of his proposal, a surety bond or bonds, acceptable to the Purchaser, as security for the faithful performance of the contract, including the payment of all persons performing labor on the project and the furnishing of all materials required to be furnished by him/her in connection with the contract. The bond or bonds shall be for the full amount or the contract price and shall remain in effect until two (2) years after the acceptance of the work by West Sound Utility District.

PAYMENTS TO CONTRACTOR: All payments to the contractor for services performed on this project will be within 30 calendar days of District approval of the contractor invoices.

EXECUTION OF CONTRACT: Within fifteen (15) days after receiving contract documents from Purchaser, the successful bidder will be required to execute said contract and furnish a performance bond.

CONTRACT DOCUMENTS

All documents have been included for informational purposes. West Sound Utility District will forward the required documents not required for proposal submission to the awarded contractor.

PUBLIC WORKS CONTRACT

Parties: WEST SOUND UTILITY DISTRICT &

THIS IS AN AGREEMENT entered into between West Sound Utility District, a Washington State Municipal Corporation, hereinafter called "District," and _____, hereinafter called "Contractor."

Pursuant to its resolutions and procedures, the District has determined the Contractor to be the lowest responsible bidder to perform the services hereinafter described. The purpose of this document is to set forth the specific terms of the parties' agreement in writing.

NOW, THEREFORE, in consideration of the foregoing recitals and the promises and covenants of the parties hereinafter set forth, they agree as follows:

1. Services to be performed by Contractor. The services to be performed are identified in the attached plans and specifications, referred to as Attachment "A" which by this reference is incorporated herein. In performing its work, the Contractor shall supply all necessary labor and materials to fully and completely finish the work called for herein.

2. Payment for Services. The total payment from the District to the Contractor for the work to be performed by the Contractor as described herein shall be **the total sum of \$ _____ plus applicable Washington State sales tax.** Payment of this said amount shall be due and owing within forty-five days of the completion of the work by the Contractor and acceptance by the District. Acceptance shall not be unreasonably withheld.

3. Commencement/Completion of Work. **The contractor shall commence its work for the District on or before _____ . All work called for herein shall be fully completed by the Contractor on or before _____ .**

4. Contractor Representations. The Contractor hereby represents and warrants to the District as follows:

A. Bonding Company and License No. The Contractor is fully licensed, bonded, and in good standing with the State of Washington.

- 1) It's Contractor License Number. with Washington State is _____
- 2) It is currently bonded with the following bonding company to do business in the State of Washington
 - a) Bond No. _____.
 - b) This bond was issued on the ____, day of _____, 20__.

3) In addition to the above, the Contractor is required to provide a Performance Bond and Payment in accordance with the Prevailing Wage regulations prior to the commencement of work.

B. Evidence of Insurance. Prior to performing its construction work, the Contractor shall provide the District with written evidence of insurance covering public liability and property damage concerning the work to be performed. If the total amount of services to be performed by the Contractor exceeds five thousand and 00/100 dollars (\$5,000.00) the coverage limits for liability shall be not less than as set forth on Attachment "B" entitled "Minimum Requirements for Certificates of Insurance" which by this reference is incorporated herein and made a part hereof.

In the event Attachment "B" is applicable hereto, the Contractor shall be obligated to comply with all terms and specifications set forth therein.

C. Hold Harmless Provision. The Contractor shall indemnify, defend, and hold harmless the District, its engineer, agents, and employees from any and all claims, demands, actions, and/or liabilities of every kind and nature as may be made and/or entered against the Districts, its engineer, their agents, and employees by reason of, or arising out of, the acts or omissions of the Contractor, its agents, or employees, including costs and attorney's fees incurred by the Districts and its agents and representatives in investigating and defending against any such claims in the event of failure of the Contractor to so defend as herein required.

D. Prevailing Wages. Concerning the work called for herein, the Contractor agrees to pay hourly wages to its laborers and workers in accordance with Washington law and specifically in accordance with RCW 39.12.020 dealing with the prevailing rates to be paid on public-works projects. The Contractor represents it is fully knowledgeable concerning the terms of RCW 39.12.020. The first invoice cannot be paid until the District has received the approved Intent to Pay Prevailing Wages. Retainage shall be 5% of each invoice. Retainage cannot be released until the Affidavit of Wages Paid is approved by the State and the Department of Revenue has approved the release of funds.

E. Performance of Work. The Contractor shall perform all work in a good, workmanlike and timely fashion. All materials used by the Contractor in its work shall be of a good or superior quality. In performing its work, the Contractor shall also act in accordance with all applicable local, state, and federal laws and regulations.

F. Warranty. The Contractor represents and warrants that all services and materials used by it in its services for the District shall be completely free of defects for a period of time lasting two (2) years from the date of completion. In the event any defects are discovered within the warranty time concerning the Contractor's services or materials used by it, the Contractor shall promptly cure any said defects.

G. Non-assignment of Obligations. The contractor is hereby prohibited from assigning or in any manner transferring its obligations under this contract to any third party or entity. The Contractor shall be personally responsible for performance of all work and obligations placed upon it hereunder. The person in charge of the Contractor's work hereunder shall be _____, and he/she shall make him or herself available to the District representative at all reasonable time for consultation.

H. District Inspection. Prior to commencing its work, the Contractor shall meet with the District representative(s) and these parties shall set forth an inspection schedule to be followed by the District in inspecting the Contractor's work while it is in progress. The contractor shall promptly report to the District, in writing, all errors and omissions it commits in performing the work.

5. Risk of Loss. Until the Contractor's work for the District has been fully completed and accepted by the District, all risk of loss concerning the project shall be borne by the Contractor.

6. Cooperation of Parties. The parties shall strive at all times to cooperate with one another in good faith so the terms and spirit of this agreement may be carried out in a good and timely manner.

7. Legal Action. In the event either party employs an attorney to enforce or defend any claim or cause of action arising out of or relating to this agreement, or any appeal therefrom, then and in any such event, the prevailing party shall be entitled to recover from the losing party, and the losing party shall pay, all of the prevailing parties reasonable costs and attorney fees therein incurred. The venue and jurisdiction for any such action shall lie with the appropriate court in Kitsap County, Washington.

8. Complete Agreement. This agreement constitutes the full and complete agreement between the parties concerning the matters set forth herein. There are no other agreements, either written or verbal, in existence.

DATED this _____ day of _____, 20_____.

WEST SOUND UTILITY DISTRICT:

Glen R. Screws, General Manager

CONTRACTOR:

PERFORMANCE AND PAYMENT BOND

KNOW ALL MEN BY THESE PRESENTS: THAT whereas West Sound Utility District, Port Orchard, Washington a municipal corporation has awarded to:

(Contractor)

hereinafter designated as the “Principal”, a contract for work items, which contract consists of the Proposal/Agreement, together with the Contract Documents, Specifications, Addenda and Plans, all as hereto attached and made a part hereof, and more particularly described as:

and whereas said principal is required under the terms of said contract to furnish a bond for the faithful performance of said contract:

NOW, THEREFORE, we the Principal and _____, a corporation, organized and existing under and by virtue of the laws of the State of Washington, and duly authorized to do business in the State of Washington as surety, are firmly bound unto West Sound Utility District in the sum of _____ lawful money of the United States, for the payment of which sum well and truly to be made, we bind ourselves, our heirs, executors, administrators, successors and assigns, jointly and severally, firmly by these presents.

THE CONDITION OF THIS OBLIGATION IS SUCH, that if the above bonded principal, his or its heirs, executors, administrators, successors or assigns, shall in all things stand to and abide by, and well and truly keep and perform the covenants, conditions and agreements in said contract, and shall faithfully perform all the provisions of such contract, and shall also well and truly perform and fulfill all the undertakings, covenants, terms, conditions and agreements of any and all duly authorized modifications of said contract that may hereafter be made, at the time and in the manner therein specified; and shall pay all laborers, mechanics, subcontractors and materialmen, and all persons who shall supply such person or persons, or subcontractors, with provisions and supplies for the carrying on of such work on his or their parts; and shall indemnify and save harmless the Owner's Engineer, its officers and agents, from any loss or damage occasioned to any person or property by reason of any careless or negligence on the part of said principal, or any subcontractor, in the performance of said contract or any modifications thereof; and shall further indemnify and save harmless West Sound Utility District, its officers and agents, from any damage or expense by reason of failure of performance as required by said contract, or any modifications thereof, or from defects appearing or developing in the material or workmanship provided or performed under said contract within a period of two years after acceptance thereof by West Sound Utility District, then this obligation shall become null and void, otherwise it shall be and remain in full force and effect.

And the said surety, for value received, hereby further stipulates and agrees that no change, extension of time, alteration or addition to the terms of the contract or to the work to be performed thereunder or the specifications accompanying the same shall in any way affect its obligation on this bond, and it does hereby waive notice of any change, extension of time, alternations or additions to the terms of the contract or the work or to the specifications.

IN WITNESS THEREOF, the said Principal and the said surety caused this bond and three (3) counterparts thereof to be signed and sealed by their duly authorized officers, this _____ day of _____, 20__.

Principal

By_____

Title_____

ATTEST (If Corporation)

WITNESSES (If Individual or Partnership)

CORPORATE SEAL

By_____

Title_____

Address of local office and agent of Surety Company is:

**WEST SOUND UTILITY DISTRICT
BID BOND FORM**

Herewith find deposit in the form of a certified check, cashier's check, or cash in the amount of \$ _____ which is **not less than five percent (5%) of the total bid.**

Sign Here: _____

BID BOND

Know all men by these presents, that we _____ as Principal and _____ as Surety, are held and firmly bound unto WSUD, as obligee in the penal sum of _____ dollars, for the payment of which the principal and the surety binds themselves, their heirs, executors, administrators, successors and assigns, jointly and severally, by these presents.

The condition of the obligation is such that if the obligee shall make any award to the principal for _____, according to the terms of the proposal or bid made by the principal therefore, and the principal shall duly make and enter into a contract with the obligee in accordance with the terms of said proposal or bid award and shall give bond for faithful performance thereof, with surety or sureties approved by the obligee; or if the principal shall, in case of failure to do so, pay and forfeit to the obligee the penal amount of the deposit specified in the call for bids, then this obligation shall be null and void; otherwise it shall be and remain in full force and effect and the surety shall forthwith pay and forfeit to the obligee, as penalty and liquidated damages the amount of this bond.

Signed, sealed, and dated this _____ day of _____, 20_____.

Principal: _____

Surety: _____

Return of deposit in the amount of
\$ _____

Date: _____ By: _____

INSURANCE REQUIREMENTS:

Public Liability and Property Damage Insurance

General Requirements

1.1 The Contractor shall obtain and keep in force during the term of the contract, Commercial General Liability and Automobile liability insurance policies with insurance companies which have an A.M. Best's rating of A-: VII or better and who are approved by the Insurance Commissioner of the State of Washington pursuant to Title 48 RCW. All insurance coverage required by these specifications shall be written and provided by "occurrence-based" policy forms rather than "claims made" forms.

1.2 Prior to the execution of the contract, the Contractor shall purchase and maintain during the term of this project a Commercial General Liability insurance and Automobile insurance policies meeting the requirements set forth herein. The Contractor shall file with the District **either** a certified copy of all policies **with endorsements attached**, or a certificate of insurance **with endorsements attached** as are necessary to comply with these specifications. Failure of the Contractor to fully comply with the requirements regarding insurance will be considered a material breach of contract and shall be cause for immediate termination of the contract and of any and all District obligations, regarding same.

1.3 The Contractor shall not begin work under the contract or under any special condition until all required insurances have been obtained and until such insurances have been approved by the District. The insurance shall provide coverage for the Contractor, the Contractor's agents and employees, subcontractors, and the District. The coverage so provided shall protect against claims from bodily injuries, including accidental death, as well as claims for property damage which may arise from any act or omission of the Contractor, the Contractor's agents and employees, subcontractors, or by anyone directly or indirectly employed by either of them.

1.4 The insurance policies shall specifically name the District, its elected and appointed officials, officers, employees, agents and volunteers as additional insureds with regards to damages and defense of claims arising from: (a) activities performed by or on behalf of the Contractor; (b) products and completed operations of the Contractor, and (c) premises owned, leased or used by the Contractor. The insurance shall be maintained in full force and effect at the Contractor's expense throughout the term of the contract. Products and completed operations coverage shall be maintained for a minimum of three years after completion of the project.

1.5 The District shall be given at least 45 days written notice of any cancellation, nonrenewal, material reduction, or modification of coverage. Such notice shall be by *certified mail* to the District.

1.6 The coverages provided by the Contractor's insurance policies shall be primary to any insurance maintained by the District, except as respects losses attributable to the sole negligence of the District or otherwise limited in accord with the provisions of RCW 4.24.115. Any insurance that might cover this contract that is maintained by the District shall be in excess of the Contractor's insurance and shall not contribute with the Contractor's insurance.

1.7 The Contractor's insurance policies shall protect each insured in the same manner as though a separate policy had been issued to each. The inclusion of more than one insured shall

not affect the rights of any insured as respects any claim, suit or judgment made or brought by or for any other insured or by or for any employee of any other insured. However this provision shall not increase the limits of the insurer's liability.

1.8 The General Aggregate provision of the Contractor's insurance policies shall be amended by endorsement to show that the General Aggregate Limit of the policies applies separately to this project.

1.9 The Contractor's insurance policies shall not contain deductibles or self-insured retentions in excess of \$10,000 unless approved by the District.

1.10 The Contractor's insurance policies shall contain a provision that the District has no obligation to report events which might give rise to a claim until a claim has been filed with the District's Board of Commissioners.

1.11 Types and Limits of Insurance Required:

Commercial General Liability

- \$2,000,000 each occurrence Bodily Injury and Property Damage liability
- \$2,000,000 annual aggregate
- Employees and volunteers as Additional Insureds
- Premises and operations
- Broad form property damage including underground, explosion and collapse hazards (XCU)
- Products completed operations (shall be maintained for at least three years after completion.)
- Blanket contractual
- Subcontractors
- Personal injury with employee exclusion deleted
- Employers liability (Stop gap)

Automobile Liability

- \$2,000,000 per accident bodily injury and property damage liability, including
- Any owned automobile
- Hired automobiles
- Non-owned automobile

Umbrella Liability (applicable to both the Commercial General and Auto Liability coverage and employers liability, provided this requirement may be satisfied through the Contractor's primary commercial general and auto liability coverage, or any combination thereof.

- \$2,000,000 per occurrence
- \$2,000,000 aggregate

1.12 Providing coverages in the stated amounts shall not be construed to relieve the Contractor from liability in excess of such limits.

1.13 The Contractor shall have its insurance agent/representative complete the Insurance Coverage Questionnaire contained in the proposal and attach it to the certificate of insurance for District's approval.

1.14 The Contractor shall maintain Workers Compensation insurance and/or Longshore and Harbor Workers insurance (or Jones Act coverage for all employees eligible for same) as required by state or federal statute for all of the Contractor's employees to be engaged in work on the project under this contract and, in case any such work is sublet, the Contractor shall require the subcontractor similarly to provide workers compensation insurance and/or longshore and harbor workers insurance (or Jones Act coverage) for all of the subcontractor's employees to be engaged in such work. The Contractor's Department of Labor & Industries account number shall be noted on the certificate of insurance. In the event any class of employees engaged in the work under this contract is not covered under Workers Compensation insurance or Longshore and Harbor Workers insurance (or Jones Act coverage) as required by state and federal statute, the Contractor shall maintain and cause each subcontractor to maintain, Employers Liability insurance for limits of at least \$1,000,000 for each employee for disease or accident, and shall furnish the District with satisfactory evidence of such.

1.15 The Contractor shall be solely and completely responsible for safety and safety conditions on the job site, including the safety of all persons and property during performance of the work. The services of District employees or the engineer's personnel in conducting construction review of the Contractor's performance is not intended to include review of the adequacy of the Contractor's work methods, equipment, bracing, scaffolding, or trenching, or safety measures in, on, or near the construction site. The Contractor shall provide safe access for the District and its inspectors to adequately inspect the quality of work and the conformance with project specifications.

1.16 The Contractor shall be solely and completely responsible to perform all work and furnish all materials in strict compliance with all applicable state, city, county and federal laws, regulations, ordinances, orders and codes. The Contractor's attention is directed to the requirements of the Washington Industrial Safety and Health Act (WISHA), Chapter 49.17 RCW.

1.17 The District will make no progress payments until the Contractor has fully complied with this section. This remedy is not exclusive and the District may take such other action as is available under other provisions of this contract, or otherwise in law.

1.18 The contractual coverage of the Contractor's policy shall be sufficiently broad enough to insure the provisions of the **HOLD HARMLESS AND INDEMNIFICATION AGREEMENT** of this contract.

1.19 Nothing contained in these insurance requirements shall be construed as limiting the extent of the Contractor's responsibility for payment of damages resulting from the Contractor's operations under this contract.

SUBCONTRACTORS

The Contractor shall ensure that each subcontractor of every tier obtains and maintains at a minimum the insurance coverages listed above. Upon request of the District, the Contractor shall provide evidence of such insurance.

EVIDENCE OF INSURANCE

The Contractor shall provide to the District a certificate(s) of insurance and endorsements for each policy of insurance meeting the requirements set forth herein when the Contractor delivers the signed contract to the District for the work. The certificate and endorsements shall conform to the following requirements:

1. An Acord certificate or a form determined by the District to be equivalent. The certificate or an endorsement form shall indicate the Contractor's insurance is primary and non-contributory.
2. The Contractor shall obtain endorsement forms CG 20 10 10 01 and CG 20 37 10 01, or the equivalent of each, naming the District and all other parties listed herein as Additional Insured(s) and providing the policy number. If the Contractor is unsuccessful in securing these endorsements after exerting commercially reasonable efforts, the Contractor shall obtain other endorsements providing equivalent coverage to the Additional Insured, subject to the review and approval of such other endorsement forms by the District. A statement of additional insured status on an Acord certificate of insurance shall not satisfy this requirement. Commercially reasonable efforts shall be evidenced by a signed statement by the Contractor's insurance broker certifying the endorsement forms required by the District are not available and the endorsements submitted provide equivalent coverage to the Additional Insured.
3. Any other amendatory endorsements to show the coverage required herein.

NOTE: THIS QUESTIONNAIRE MUST BE COMPLETED AND ATTACHED TO CERTIFICATE OF INSURANCE AND POLICY ENDORSEMENT.

Insurance Coverage Questionnaire

For _____
(Name of Insured)

Project Number _____

Project Owner _____

Are the following coverages &/or conditions in effect?		
	Yes	No
The Policy form is ISO Commercial General Liability (CGL) form CG 00 01 of CG 00 02 (circle one). If No, attach a copy of the policy with required coverages clearly identified.		
(CGL) Ongoing Operations coverage (similar to CG 20 10 10 01, CG 2010 07 04, or equivalent)		
(CGL) Products and Completed operations coverage (similar to CG 20 37 07 04, CG 20 37 07 04, or equivalent)		
Personal Injury Liability Coverage. (with employee exclusion deleted)		
Broad Form Property Damage with X, C, U Hazards included		
Blanket Contractual Liability coverage applying to this contract		
Employers Liability - Stop Gap		

Deductibles or SIRs: GL _____ AL _____ Excess _____

Insurer' Best Rating GL _____ AL _____ Excess _____

This Questionnaire is issued as a matter of information. This questionnaire is not an insurance policy and does not amend, extend or alter the coverage afforded by the policies indicated on the attached Certificate of Insurance.

Agency/Broker

Completed by (type)

Address

Completed by (Signature)

Name of Person to contact

Telephone Number

ATTACHMENT "B"
MINIMUM REQUIREMENTS FOR
CERTIFICATES OF INSURANCE

COMMERCIAL GENERAL LIABILITY

Bodily Injury	\$500,000 each person
	\$2,000,000 each occurrence
Property Damage	\$2,000,000 each occurrence
	\$4,000,000 gen. aggregate
or	
Combined Single Limit	\$2,000,000 each occurrence
	\$4,000,000 gen. aggregate
Employers Liability	\$2,000,000 each accident
	\$1,000,000 each employee - disease
	\$1,000,000 policy limit - disease

AUTOMOBILE LIABILITY

Bodily Injury	\$500,000 each person
	\$2,000,000 each occurrence
Property Damage	\$2,000,000 each occurrence
or	
Combined Single Limit	\$2,000,000 each occurrence

WORKERS COMPENSATION

Limits	Statutory (show L & I ID #)
--------	--------------------------------

Certificates shall be issued through insurance companies licensed to do business in the State of Washington pursuant to Title 48 RCW and who have a "Best's Insurance Guide" rating of not less than A+VII

Certificates of Insurance must be on file with the Districts prior to the start of any operations within the District.

1. GENERAL INFORMATION

West Sound Utility District, herein referred to as the Owner, requires the cleanout and redevelopment of their Well 22. Well 22 is a 16-inch diameter well located at 2823 SE Lund Avenue in Port Orchard, Washington 98366. The well was drilled in 2010 to a depth of 1,525 feet with 16-inch casing and is completed with a 21-foot, 10-inch diameter tailpipe from 1,476 to 1,497 feet below ground surface (bgs) and 140 feet of 10-inch diameter, 30-slot, stainless-steel screen set from 1,336 to 1,476 feet bgs. The 10-inch diameter riser assembly extends up to 1,262 feet bgs and includes an unexposed, 30-slot pressure-relief screen from 1,306 to 1,315 feet bgs. The screen is packed with a filter pack of 10-20 Colorado Silica sand. A construction diagram and the water well report is attached. **Note: an abandoned surge tool and drill stem is lodged in the well between 1,469 and 1,487 feet bgs, extending upwards approximately 7 feet into the lowest screen.**

The Owner has noticed increased drawdown and reduced yields from the well since 2019. As a result, the Owner desires to have the pump removed and have the interior of the well inspected with a downhole video camera to evaluate the condition of the casing and screens prior to redevelopment. The pump (to include the motor and wire) will be replaced with new and does not require evaluation, but the Contractor will evaluate the pump column and check valves for reuse; all equipment is to remain the property of the Owner. Next, the well will be cleaned out and mechanically redeveloped, which at different stages will include both a phosphate-free dispersant (e.g., Aqua-Clear PFD) and disinfection with a pH-balanced chlorine product (e.g., Sterilene) to address possible biofouling within the well and adjacent formation material. After the disinfection process, a Contractor-supplied submersible pump will be used to pump turbid water and spent chemistry to the District's sanitary sewer located on SE Lund Avenue, approximately 180 feet from the wellhead; no separate post-disinfection neutralization of the residual chlorine will be required. A post-redevelopment video inspection will then be conducted to document the efficacy of redevelopment activities.

A new submersible pump and motor will need installed in the well from its current depth of 500 feet bgs at an anticipated depth of 640 feet bgs. Once the pump has been removed from the well and the column and check valves have been evaluated, the Contractor shall prepare a complete inventory of the materials required for pump installation for review by the Owner. The Contractor will install the equipment at the conclusion of well redevelopment and video inspection activities, verify equipment operation, and reconnect the well to the District's system. The District's electrician can be available to make the submersible splice to the motor's pigtails and make electrical connections to the existing VFD, if desired. Note that for the purposes of bid comparison, the hours indicated on the bid sheet for this task will be taken into account.

Robinson Noble, Inc., herein called the Geologist, shall direct work for the Project and act as the Owner's representative in all activities associated with the cleanout and redevelopment of the well. The Owner will provide access to the site prior to mobilization, if needed. Spoils bailed from the well will be collected on a tarp provided by the Contractor for subsequent disposal by the Owner. Potable water for redevelopment and video inspection activities will be provided on site. The well is inside of a building without direct line-of-sight from the anticipated rig position. The building has skylight access to the well, but the skylight is not centered over the well. Based on prior well work, however, it is anticipated that a typical cable-tool rig can set up over the well. Potential contractors are encouraged to arrange for a site visit to verify equipment access prior to submitting a bid.

2. SCOPE OF WORK

The intent of this contract is to remove the existing pump, perform a pre-redevelopment video inspection, clean out and redevelop the screens, perform a post-redevelopment video inspection, and then install the new pump equipment once cleanout and redevelopment is complete. The cleanout and redevelopment will be a physical approach using surge-and-bail methods accomplished via a cable-tool drilling rig or a sufficiently-sized pump hoist equipped with a spudding mechanism and a tool stem of sufficient weight to impart energy into the screen on the tool's down stroke.

Well cleanout and redevelopment shall be performed in accordance with applicable requirements of Washington Administrative Code (WAC) 173-160 and the requirements of these specifications. Where the requirements of these specifications are more stringent, the requirements of the specifications shall prevail, provided that nothing in these specifications shall be construed to require work in violation of the WAC.

3. EQUIPMENT AND MATERIALS

3.1 DRILLING MACHINE (RIG): Cleanout and redevelopment shall be accomplished by surge-and-bail methods only. If a cable-tool rig cannot access the well, a pump hoist is an acceptable alternative to a cable-tool drilling rig provided it has a spudding mechanism and can operate tools of a sufficient size and weight to effectively clean and redevelop the well. All appurtenant equipment including, but not limited to, bailers, brushes, and swabs are to be considered as part of the rig, available to the project as needed, and delivered to the site as a function of project mobilization.

4. EXECUTION OF WORK

4.1 COMPLETION TIME: All work shall be completed as coordinated and identified within the contract with the District for the specified work. The project starting time shall be coordinated with the Owner. There shall be no work performed on holidays or weekends unless approval for such work is granted by the Owner and Geologist. Requests for extended work hours or days shall be made at least 24 hours prior to that requested time. Exceptions may be granted in emergency situations where it is clear and agreed to by all parties that project progress would be significantly threatened by a holiday/weekend delay or to allow the contractor to affect repairs on equipment to ensure continued project progress on the next regular workday. It shall be the responsibility of the Contractor to keep the Owner and the Geologist informed of any intent to change the normal work schedule. Such notification shall be timely to avoid either's travel to an inactive drilling rig.

4.2 SITE PREPERATION AND RESTORATION: The Contractor is responsible for any needed site preparation, as well restoration of any damage to the site as a result of Contractor's activities. The site is fenced and gated. The gate must be locked when the site is not occupied.

4.3 CLEANOUT AND REDEVELOPMENT: The cleanout and redevelopment of the well shall be as directed by the Geologist. The Owner and Geologist will coordinate with the Contractor so that the video inspection of the interior of the well can be completed as soon as possible after the pump is removed. The Owner requires a 72-hour notice prior to starting work

to allow for this coordination. Following pump removal, the Contractor shall flush the well with potable water, provided by the Owner, for a minimum of eight hours prior to the video inspection to improve water column visibility. After the video inspection, cleanout shall include the brushing of the interior of the well casing and screens to remove loose scale and encrustation, then bailing any accumulated material (above the abandoned tooling) from the well with a sand-pump bailer.

Following brushing, mechanical redevelopment shall be accomplished by surging of the screens station-by-station with surge discs on the drill stem. Due to the anticipated position of the abandoned surge tool lodged in the well, surging of the bottom 8 to 10 feet of screen will likely not be possible. The Contractor will have NSF-certified phosphate-free dispersant (e.g., Aqua-Clear PFD) and buffered chlorine products (e.g., Sterilene), sufficient to dose the well twice with each per the manufacturer's specifications, on-site and available to the project, if needed. Accumulated material above the abandoned tooling will be removed from the well with a sand-pump bailer or other means (e.g., water jetting, air-lift pumping) as deemed appropriate by the Geologist. The driller shall measure and tabulate accumulations of material with a tagline at the beginning and end of each day and between surge passes.

After the disinfection process, a Contractor-supplied submersible pump capable of at least 100 gpm from a depth of 500 feet bgs will be used to pump turbid water and spent chemistry to the District's sanitary sewer, located on SE Lund Avenue, approximately 180 feet from the wellhead; no separate post-disinfection neutralization of the residual chlorine will be required.

At all times during the work, the Contractor shall have on hand a supply of chlorine solution or dry chlorine. Chlorination shall be done as directed by the Geologist or as desired by the Contractor such that disinfection of the drill string and materials is accomplished. No extra payment is authorized for normal chlorination.

Following the completion of cleanout and redevelopment, the Owner and Geologist will coordinate with the Contractor for the final video inspection of the interior of the well screen to evaluate the results of the cleanout and redevelopment effort. The Contractor shall again flush the well with potable water, provided by the Owner, for a minimum of eight hours prior to the video inspection to improve water column visibility. Upon the satisfactory completion of cleanout and redevelopment activities, the Contractor will install the pump equipment and reconnect the well to the District's system.

Following the installation of the new pump, the water will be pumped until clear to allow for the collection of a bacteriological sample for Washington State Department of Health compliance. Upon receiving satisfactory bacteriological sample results, District staff will hydraulically connect Well 22 to the system.

Well redevelopment and pump installation shall be performed by an experienced and licensed well driller and a helper. Only competent workers shall be employed on the job.

4.4 CAPPING: At all times during the progress of the work, the Contractor shall protect the well in such a manner as to effectively prevent either tampering with the well or entrance of foreign matter into it. The well is in a locked building within a fenced site that must be secured when the Contractor is not on site.

5. SUBMITTALS

5.1 DAILY LOGS: The Contractor shall keep a daily written log of operation, including: tools used; depth to water at the beginning and end of the shift; pumping rates and durations; use and application rate of any chemistry; and progress of development work, including all observations of filter pack level and accumulated development spoils. A duplicate copy of the daily log shall be furnished to and approved by the Geologist no later than the beginning of the following day's work.

5.2 PROJECT INVOICES: The Contractor will provide the Geologist with a copy of each invoice prior to submittal to the Owner. The Geologist will review the invoice for accuracy. The Contractor will allow sufficient time for this review such that the Owner's schedule submittal of invoices can still be met.

6. MEASUREMENT AND PAYMENT

6.1 MOBILIZATION AND DEMOBILIZATION: The lump sum price established in the bid proposal for Mobilization, Clean Up and Demobilization shall be billable at the rate of 70% of price bid when drilling starts and the final 30% when all equipment and materials are removed from the site and the site is left in a clean and orderly state. This item includes all compensation for site preparation and restoration.

6.2 AUTHORIZED RIG WORK: Any directed work that requires a fully operating rig and a minimum of a two-person crew and is not otherwise covered by unit prices herein shall be paid at the rig hourly rate provided in the bid proposal. No extra payment for rig hourly work shall be made when equipment being used is not in good working condition. Pump removal, inspection, and installation are included in the hourly scope. No payment will be authorized for standby time during the video inspection(s).

6.3 TEST PUMP: Provision of the submersible test pump specified in Item 4.3 includes installation, removal, and pumping for four (4) hours to the District's sanitary sewer. Specified accessories and transmission lines are considered to be part of the pump unit. Unless otherwise authorized, this item is to be used only once per well. Additional removal and resetting in the same well would be covered under Item 7.2. Price bid includes provision of an accepted discharge method for water pumped, such as a meter, orifice weir, or other means of accurate flow measurement; a valve or other means to adjust flow rate; and 200 feet of discharge line to escort water to the point of disposal.

6.4 EXTRA MATERIALS: Materials not otherwise herein specified shall be provided only as directed and shall be paid for at documented cost plus 15% handling. Extra materials include but are not limited to filter pack, phosphate-free dispersants (e.g., Aqua-Clear PFD) to help remove fine formation material, and buffered chlorine products (e.g., Sterilene) for well disinfection.

**BID PROPOSAL
FOR WEST SOUND UTILITY DISTRICT'S WELL 22**

Item	DESCRIPTION	Units	Price Per Unit	Estimated Total Cost for Bid Comparison
1	Mobilization and Demobilization	One	Lump Sum	
2	Authorized Rig work	200 Hours	\$_____/HR	
3	Test pump installation, removal and pumping (4 hours)	One	Lump Sum	
4	Contractor supplied pump equipment (Pump, motor, wire, additional column etc.)	One	Lump Sum	
6	Extra Materials, supplies (Cost plus 15%)	One	Lump Sum Estimated at \$1,500	

Base Bid Total _____

Time and Materials Not to Exceed (In words):

Will the District's electrician be requested to make pump and VFD connections?

Yes _____ / No _____

If yes, approximately how many Contractor hours will this save?

Proposed Date to Begin Site Activities:

Firm Name:

By:

7. GENERAL PROVISIONS

7.1 TIME FOR COMMENCEMENT AND COMPLETION: The Contractor shall notify West Sound Utility District 48-hours prior to the time of commencement of his work and the work shall be commenced and completed as set forth in the Contract.

7.2 CLAIMS FOR DAMAGE: The Contractor shall not be entitled to any claim or damages on account of hindrance or delays from any cause whatsoever; but if occasioned by causes beyond the control of the Contractor, or by any act or omission on the part of the Purchaser, such act, hindrance, or delay may entitle the Contractor to an extension of time in which to complete the work, provided that the Contractor gives notice in writing stating the cause of such act, hindrance or delay within two (2) days after its occurrence.

7.3 PAYMENTS: The Contractor shall submit invoices to the District at the end of the project for the services performed. Payments will be made no later than thirty (30) calendar days upon acceptance and District approval of the Contractor's invoice.

Retention of Public Works Contracts: Five percent (5%) of all monies earned by the Contractor on estimates during the progress of the work shall be retained by the District. Said funds shall not be released until the expiration date of thirty (30) days after the acceptance of the completed contract and the receipt of a certificate from the proper authorities. The Contractor shall certify that there are no unsatisfied liens against the fund. Certificates shall be obtained from the State Tax Commission, and any suppliers of labor, material, or equipment as requested by the District.

- Prior to release of retainage, the Contractor shall provide the following:
- Affidavit of Wages Paid from Department of Labor
- Certificate from the Department of Revenue that all taxes and penalties are paid.
- Certificate from Contractor that all suppliers and subcontractors have been paid and that there are no liens against the project.

7.4 INTERPRETATIONS OF DOCUMENTS: The documents forming the contract are complementary, and what is called for in one shall be binding as if it were called for by all. They are intended to include all details and material reasonably necessary for the proper execution of the work.

7.5 PROTECTION OF LIFE AND PROPERTY, AND INDEMNITY AGREEMENT:

a. Responsibility for the protection of the work, the workers, all public utilities, the public at large, and traffic in general against damage and injury chargeable to the construction or any circumstances, conditions, or negligence in connection therewith, shall rest with the Contractor and he shall be liable therefore. The Contractor shall erect and maintain good and sufficient guards, barricades, signs, lights, and signals at all unsafe places at or near the work, and shall do all other things necessary to prevent accident or loss of any kind as a result of his operations.

b. The Contractor covenants that he will indemnify the Purchaser from any loss, damage, cost, charge, or expense whether to persons or property to which the Purchaser may have been put by reason of any act, action, neglect, omission, or

default on the part of the Contractor. The Contractor hereby covenants to assume the defense thereof and to pay any and all judgments that may be incurred by or obtained against the Purchaser.

7.6 CHANGES IN WORK AND EXTRA WORK: The right is reserved without impairing the contract, to order the performance of such extra work of a class not contemplated in the proposal, as may be considered necessary to complete fully and satisfactorily the work included in the contract. Such changes and extra work shall be done in accordance with the Contract Documents insofar as the contract documents are applicable and shall be paid for as provided for herein. Payments for extra work will be made at unit price bid, if applicable, or at cost plus fifteen percent (15%). The Contractor shall not commence or perform any extra work for which he expects extra compensation until such work has been ordered in writing by the District. All claims for extra work must be approved by the District in writing at the completion of such work.

7.7 CONTRACTOR RESPONSIBILITY FOR WORK DONE: The Contractor shall furnish for the price bid all skill, labor, and materials required for the complete performance of the contract, and shall fully complete the work. He/she shall be responsible for the entire contract and shall maintain the same during construction and until final acceptance of the entire improvement by the Purchaser. He/she shall also replace and make good any and all defective materials or workmanship in any part of the work or equipment covered by this contract if discovered within two (2) years following acceptance of the work. The performance bond furnished shall guarantee such replacement and repair and shall save harmless and indemnify the Purchaser from such defective materials or workmanship for a period of two (2) years following the acceptance of the work.

7.8 CLEANING UP: From time to time as may be ordered by the Purchaser, the Contractor shall, at his own expense, clean up and remove all refuse and unused materials of any kind resulting from the work.

7.9 TERMINATION FOR BREACH: Should the Contractor, at any time, refuse, or neglect to supply a sufficient number of properly skilled workmen or of materials of the proper quality, or fail in any respect to prosecute the work with promptness and diligence, or fail in the performance of any of the agreements therein contained, the Purchaser may, at its option and after giving ten (10) days notice in writing to the Contractor, provide such sufficiency of labor or materials and deduct the cost thereof from any monies due or thereafter to become due under this contract.

In the event of such refusal, neglect or failure, or if the Contractor abandons the work undertaken under this contract, the Purchaser may, at its option, transfer the employment for said work from the Contractor to the surety. Written notice of such transfer of employment shall be given to the Contractor and to his surety or his surety's representative, except that no notice need be given a Contractor who has abandoned work. Upon receipt of such notice, such surety shall enter upon the premises and take possession of all materials, tools, and appliances thereon for the purpose of completing the work included under this contract and employ, by contract or otherwise, any person or persons to finish the work and provide the materials therefore, without termination of the continuing full force and effect of this contract. In case of such transfer of employment to such surety, that surety shall be paid in its own name on estimates covering work subsequently

performed under the terms on this contract and according to the terms hereof without any right of the Contractor to make any claim for the same or any part thereof.

In lieu of the foregoing, if the Purchaser so elects, it may terminate the employment of the Contractor for said work and enter upon the premises and take possession of all materials, tools, and appliances thereon for the purpose of completing the work included under this contract and employ, by contract or otherwise, a person or persons to finish the work and provide the material therefore. In case of discontinuance of employment by the Purchaser as aforesaid, the Contractor shall not be entitled to receive any further balance of the amount to be paid under this contract until the work shall be fully finished, at which time, if the unpaid balance of the amount to be paid under this contract shall exceed the expenses incurred by the Purchaser in finishing the work and all damages sustained or which may be sustained by the Purchaser by reason of such refusal, neglect, failure, or discontinuance of employment, such excess shall be paid by the Purchaser to the Contractor and his surety. However, if such costs exceed the amount of the unpaid balance to be paid under this contract, the Contractor and his surety shall be jointly and severally liable therefore to the Purchaser and shall pass the difference to the Purchaser.

7.10 SCOPE OF SPECIFICATIONS: It is the intent of these specifications to describe the project complete in every respect. Any work that may have been accidentally implied, shall be furnished by the Contractor the same as if it had been specifically stated. In accepting this contract, he shall assume responsibility for methods of performing and installing the work.

7.11 PREVAILING WAGES: The Contractor agrees that the hourly minimum rate of wage which may be paid to laborers, workmen, or mechanics in each trade or occupation required by the Contractor, subcontractor, or other person doing or contracting to do the whole or any part of said work, shall not be less than the prevailing rate of wage.

The Contractor further agrees to comply with the provisions of RCW. 39.12, and in particular, to comply with the procedure for complying with said laws as set forth in the Information Bulletin dated July 19, 1965, revised January 1966 as issued by the Department of Labor and Industries of the State of Washington and any amendment or supplements thereto.

The Contractor, on or before the date of commencement of work, shall file a certificate and statement, verified by oath by the Contractor or subcontractor as the case may be, that he has read such a statement and certificate subscribed by him and knows the contents thereof, and that the same is true of his knowledge, said certificate and statement to be filed with the Purchaser and with the Director of Labor and Industries certifying the rate of hourly wage paid and to be paid each classification of laborers, workmen, or mechanics employed upon the work by the Contractor or subcontractor, which shall not be less than the prevailing rate of wage. Such statement and any supplemental statements which may be necessary shall be filed in accordance with the practices and procedures required by the Department of Labor and Industries.

In case any dispute arises as to what are the prevailing rates of wage for work of a similar nature and such dispute cannot be adjusted by the parties in interest, including labor and management representatives, the matter shall be referred for arbitration to the Director of

the Department of Labor and Industries of the State of Washington, and his decision therein shall be final and conclusive and binding on all persons involved in the dispute. West Sound Utility District retains the right to audit the Contractor's records.

Prevailing Wage Rates may be found at: <https://lni.wa.gov/licensing-permits/public-works-projects/prevailing-wage-rates/>

- The wage publication date to use is April 20, 2023,
- The project is located in Kitsap County;
- a copy of the applicable wage rates is available for viewing at West Sound Utility District Administrative Offices, 2924 SE Lund Avenue, Port Orchard, WA
- West Sound Utility District will mail a hard copy of the applicable wage rates upon request.

7.12 TAXES: The Contract Sum and any agreed variations therefrom shall include all Federal, State, and local taxes imposed by law, except for the Washington State Sales Tax, which shall be shown separately from the contract sum. Storm water facilities and paving of streets are expected to be exempt from sales tax.

7.13 MATERIALS: All materials called for shall be erected or applied in accordance with the manufacturer's instructions.

7.14 SCHEDULES AND REPORTS: The Contractor shall furnish the following schedule to the Purchaser within fifteen (15) days from the signing of the contract where practical.

- a. Schedule of all subcontractors to be used by the general contractor on this project.
- b. Department of Labor and Industries "Statement of Intent to Pay Prevailing Wages on Public Works Contract".
- c. Schedule of all materials, supplies, and labor contracts and the amounts for the same.
- d. Schedule of proposed work progress by calendar day.
- e. Upon completion of the project, execute required documents of certification of state and local government agencies as required by law for public works contracts.

8. SPECIAL SPECIFICATIONS

8.1 QUALITY ASSURANCE: The Contractor is required to remove and replace any work found deficient or not complying with the requirements of the plans and specifications, at no additional cost to the Purchaser.

8.2 SAFETY: The Contractor is required to comply with all rules and regulations of the County, and State authorities regarding job safety and any necessary traffic control. Extreme care shall be taken by the Contractor to avoid accidents.

8.3 PUBLIC SAFETY: The general contractor shall be responsible for his subcontractors in all respects insofar as this project is concerned. The Contractor shall be responsible for the erection and maintenance of good and sufficient guards, barricades, signs, lights, and signals at all unsafe places at or near the work.

9. PREVAILING WAGE PROCEDURES

Public Works construction contracts require compliance with the Prevailing Wage Laws. All contractors are encouraged to call the Department of Labor and Industries at (360) 902-5334 to obtain the required forms and to seek specific information.

The following are required:

1. The contractor shall provide the original Intent to Pay Prevailing Wages, which has been approved by L&I, before any progress payment is paid. This requires prompt submittal of the contractor's and subcontractor's forms to L&I.
RCW 39.12.040
2. Each progress payment submitted to the Purchaser shall have a statement from the contractor that the prevailing wages have been paid in accordance with the pre-filed Intent to Pay Prevailing Wages.
RCW 39.12.040
3. At the conclusion of the contract, the contractor shall provide to the Purchaser the original and L&I approved Affidavits of Wages Paid from the contractor and the subcontractors. The Purchaser will not release retainage until all approved Affidavits are received and the Department of Revenue has authorized release of retainage.
RCW 39.12.040

**WSUD Well 22
As-built Completion Design**

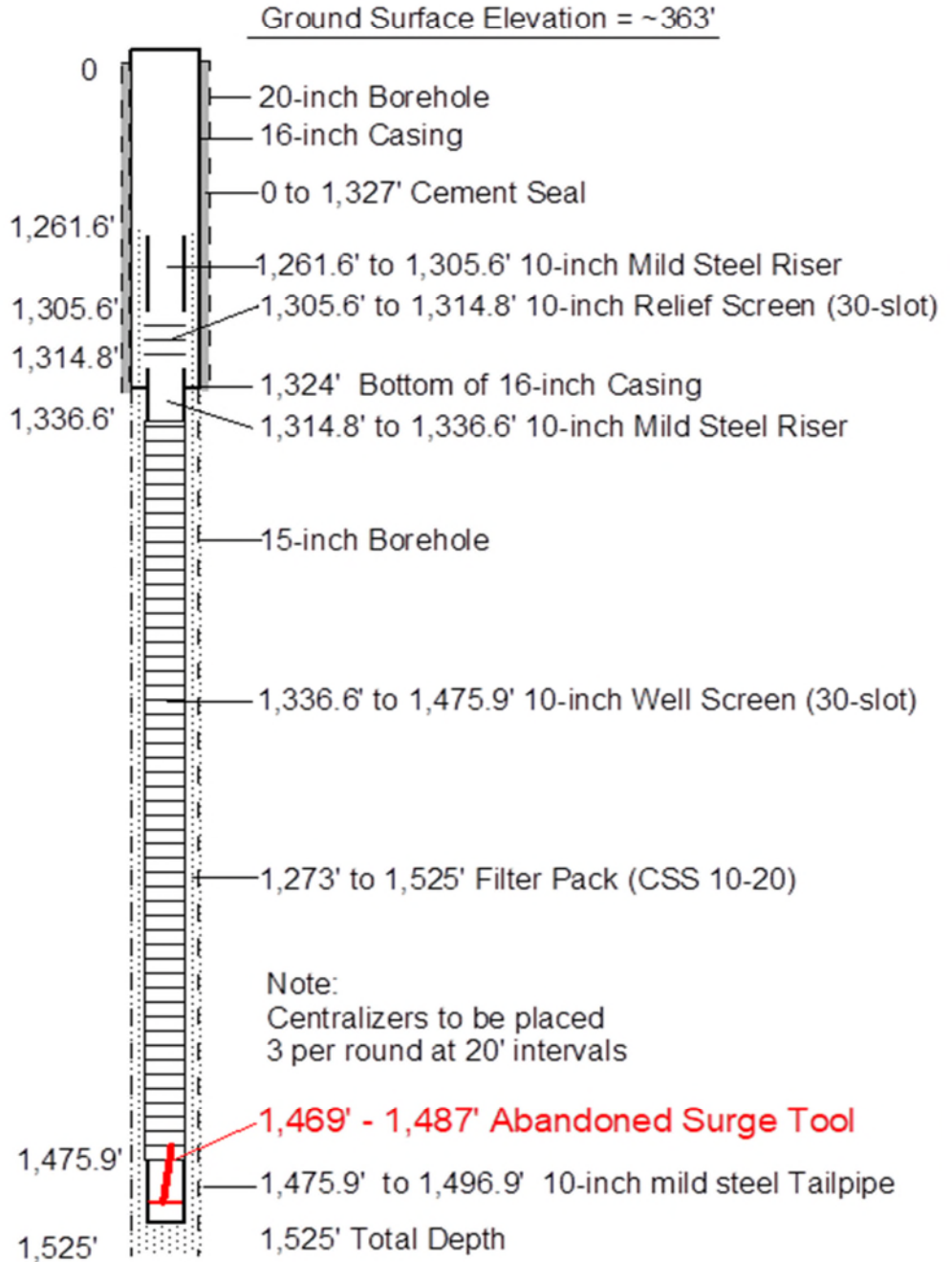

Not to Scale

Note:

Centralizers to be placed
3 per round at 20' intervals

Well Number 22 INSTALL DATE 7-17-17 District
 SALESMAN Jack, Erick PULL DATE Address
 SALES ORDER NUMBER 2446 City State Wa Zip Code

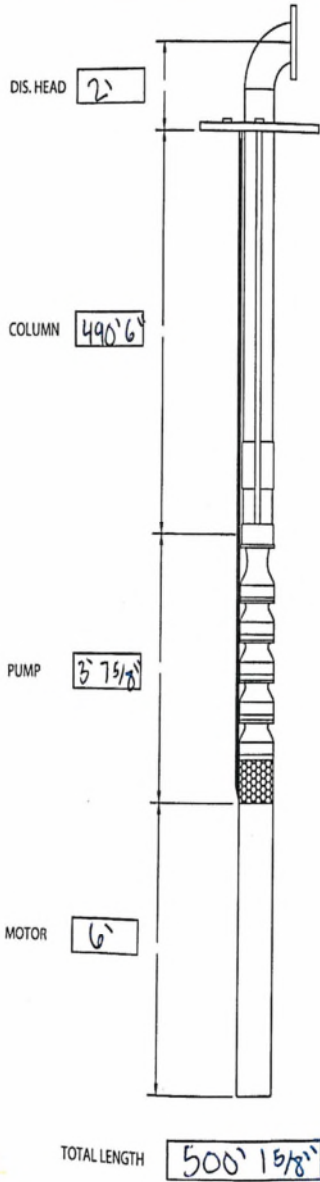

DISCHARGE HEAD SIZE 6"
 DISCHARGE HEAD DRILLING 150Lb
 WELL CASING SIZE 16"
 SOUNDING/AIR LINE SIZE 1"
 SOUNDING/AIR LINE LINE DEPTH 490' 6"
 COLUMN SIZE GAL/BLACK 6" / Coated
 CABLE SIZE 4/0
 CABLE TYPE Flat Jacket
 CHECK VALVE SIZE & NUMBER 6" (2)
 FIRST CHECK VALVE LOCATION 250' above Pump
 BOTTOM CHECK VALVE LOCATION 10' above Pump
 PUMP MANUFACTURER HydroF10
 PUMP MODEL 9CC-3
 PUMP SERIAL NUMBER TX22012
 PUMP OD 9"
 DESIGN FLOW RATE 500 gpm
 DESIGN TOTAL HEAD 602
 MOTOR MANUFACTURER Tesla
 MOTOR MODEL TR8
 MOTOR SERIAL NUMBER 60175460
 MOTOR RPM 3480
 MOTOR HORSE POWER 125
 MOTOR VOLTS & PHASE 460V/3phase
 MOTOR DIAMETER 6"

Scanned by CamScanner

Contractor supplied pump and motor data sheet specifications for reference. Owner will consider equal. If Contractor desires equal to be considered, pump and motor data sheet with pump curve shall be supplied to Owner for consideration.

Pump Data Sheet - Integrity Pump and Motor

Company: Mitchell Lewis & Slaver Co.
 Name: Pete Albanese
 Date: 3/6/2023



Pump:

Size: 7IHL (10 stage)
 Type: Submersible
 Synch Speed: 3600 rpm
 Curve:
 Specific Speeds:
 Dimensions:
 Vertical Turbine:
 Speed: 3460 rpm
 Dia: 5.57 in
 Impeller: ENCL
 Ns: ---
 Nss: ---
 Suction: 6 in
 Discharge: 6 in
 Bowl Size: 7.13 in
 Max Lateral: 0.95 in
 Thrust K Factor: 4.5 lb/ft

Search Criteria:

Flow: 500 US gpm Head: 752 ft

Fluid:

Water
 Density: 62.32 lb/ft³
 Viscosity: 0.9946 cP
 NPSHa: ---
 Temperature: 68 °F
 Vapor Pressure: 0.3391 psi a
 Atm Pressure: 14.7 psi a

Motor:

Standard: NEMA
 Enclosure: WP1
 Sizing Criteria: Max Power on Design Curve
 Size: 125 hp
 Speed: 3600 rpm
 Frame: 404TS

Pump Limits:

Temperature: 140 °F
 Pressure: 750 psi g
 Sphere Size: 0.25 in
 Power: 337 hp
 Eye Area: 11.2 in²

---- Duty Point ----	
Flow:	500 US gpm
Head:	752 ft
Eff:	80.1%
Power:	118 hp
NPSHr:	7.02 ft
---- Design Curve ----	
Shutoff Head:	1054 ft
Shutoff dP:	456 psi
Min Flow:	115 US gpm
BEP:	81.3% @ 575 US gpm
NOL Power:	120 hp @ 575 US gpm
-- Max Curve --	
Max Power:	124 hp @ 583 US gpm

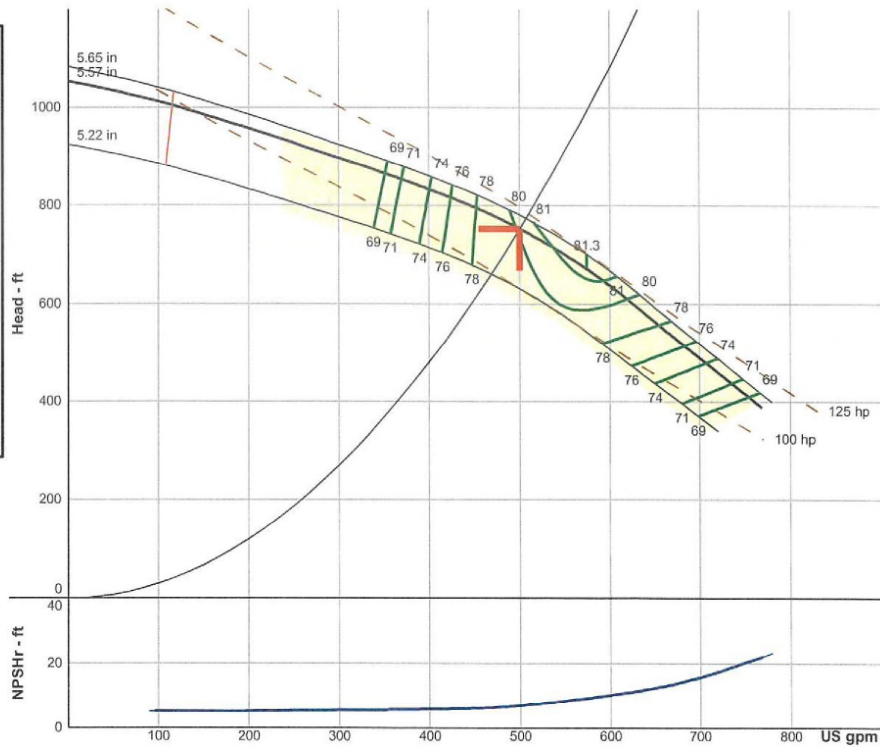

Performance Evaluation:

Flow US gpm	Speed rpm	Head ft	Efficiency %	Power hp	NPSHr ft
600	3460	637	80.7	119	10.2
500	3460	752	80.1	118	7.01
400	3460	833	74	114	5.87
300	3460	897	62.4	109	5.53
200	3460	958	46.6	103	5.24

Selected from catalog: Integrity.60 Vers: 2.1.3

** All Dimensions In Inches **
 ** NOT TO SCALE **

* NOT FOR CONSTRUCTION *

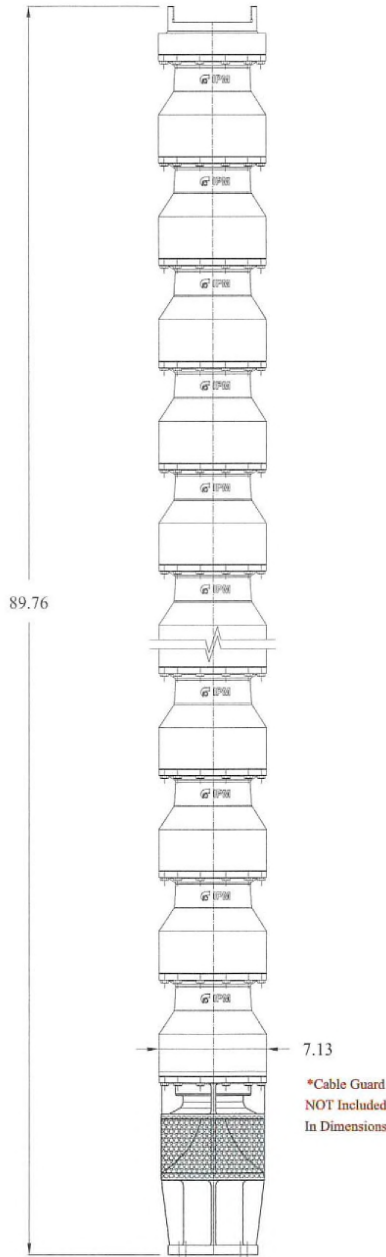

APPLICATION SPECIFICATIONS

Config #: C-14235
 Job ID:
 Pump ID:
 Conditions: 500 GPM @ 752 FT
 Nom. RPM: 3600
 Pump Type: Submersible Turbine

BOWL ASSEMBLY SPECIFICATIONS

Bowl Model: 7IHL - 10 Stage
 Discharge: 6" 1 Piece Discharge
 Impeller Model: 7IHL
 Base Materials: Ductile Iron / 201SS
 Bowl Bearings: Glide 400 Polymer
 Bowl Shaft: 1.1875" 416SS
 Motor Bracket: 8" 1 Piece Suction-Bracket
 Bracket Screen: 304SS
 Fasteners: 18-8SS
 Bracket Adapter: Not Needed

DRIVER SPECIFICATIONS

Manufacturer: None Selected
 HP, RPM:
 Phase/Volt:
 Size:
 Material:

Notes
 1.) Minimum Submergence from bottom of suction for vortex suppression: 16"
 This DOES NOT include NPSHr needs.

NOTICE This drawing is the confidential property of Integrity Pump & Motor Group, LLC (IPM) and is furnished for your information only and must not be copied or made public, and must be returned upon demand. Manufacturing parts per this drawing is expressly forbidden, except by written authorization from IPM. All rights of invention and design are reserved and patents pending.

		7112 Juniper Rd. Fairview, TN 37062 Ph: 615-544-7072	
		DESCRIPTION: 7IHL - 10 Stage Submersible Bowl Assembly	
CUSTOMER: Mitchell Lewis & Staver Co.	DRW DATE: 3/6/2023	SHEET: 1 OF 1	
WEIGHT 378 Lbs.	SERIAL No.:	CONFIG No. C-14235	REV 0

BOWL PARTS DETAIL

Bill Of Material

NOT FOR CONSTRUCTION

Item No.	Qty.	Description	Material Grade
1	1	Bowl Shaft	UNS S41600 416 Stainless Steel
10	1	Bearing - Discharge Case	Glide 400 Polymer
12	1	Discharge Case	A536 GR. 65-45-12 Ductile Iron
13	1	O-Ring - Discharge Case	ASTM D1418 BUNA-N
14	16	Bolt - Discharge Case	UNS S30400 18-8 Stainless Steel
15	1	Upthrust Bearing - **Combination Bearing/Upthrust Ring - Top Bowl Only	Glide 400 Polymer
16	10	Bowl	A536 GR. 65-45-12 Ductile Iron
17	10	O-Ring - Bowl	ASTM D1418 BUNA-N
18	10	Bearing - Bowl	Glide 400 Polymer
19	10	Collet - Impeller	UNS S31600 316 Stainless Steel
22	10	Impeller	UNS S20100 201 Stainless Steel
25	96	Bolt - Bowl	UNS S30400 18-8 Stainless Steel
40	1	Motor Bracket	A536 GR. 65-45-12 Ductile Iron
41	8	Bolt - Motor Bracket	UNS S30400 18-8 Stainless Steel
42	1	Bearing - Motor Bracket	Glide 400 Polymer
43	1	Screen - Motor Bracket	UNS S30400 304 Stainless Steel
44	1	Coupling - Submersible Motor	UNS S41600 416 Stainless Steel
46	4	Bolt - Submersible Motor	UNS S30400 18-8 Stainless Steel

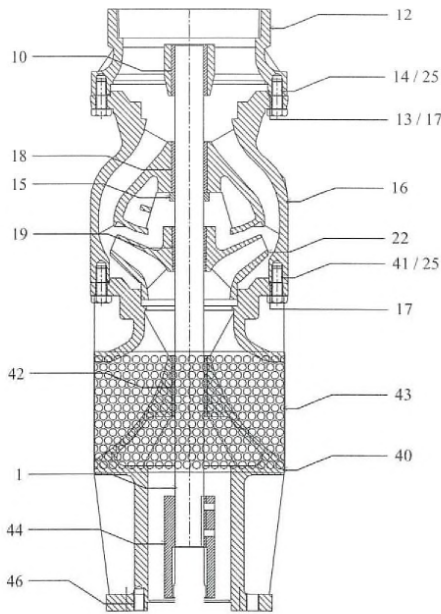

PROJECT SPECIFICATIONS

Date: 3/6/2023
 Job:
 Config #: C-14235-0
 GPM: 500
 Head FT: 752
 Pump Model: 7IHL - 10 Stage Sub
 Imp. Type: 7IHL ENCL
 Pump Materials: Ductile Iron / 201SS
 Discharge Size: 6"
 Motor Bracket Size: 8"
 Bowl Shaft Dia: 1.1875"
 Bowl Assy Weight: 343 Lbs.

DRIVER INFORMATION

Mfr: Motor Not Included
 Motor Size: 8"
 HP: 125
 RPM: 3600

INTEGRITY PUMP & MOTOR 7112 Juniper Rd.
 Fairview, TN 37062
 Ph: 615-544-7072

DESCRIPTION: 7IHL - 10 Stage
 Submersible Bowl Assembly

CUSTOMER: Mitchell Lewis & Staver Co. DRW DATE: 3/6/2023 SHEET: 1 OF 1

WEIGHT: 378 Lbs. SERIAL No.: CONFIG No. C-14235 REV: 0

NOT TO SCALE

ZOOM FOR DETAIL

NOTICE: This drawing is the confidential property of Integrity Pump & Motor Group, LLC (IPM) and is furnished for your information only and must not be copied or made public, and must be returned upon demand. Manufacturing parts per this drawing is expressly forbidden, except by written authorization from IPM. All rights of invention and design are reserved and patents pending.

SMALL WORKS CONTRACT

Parties: WEST SOUND UTILITY DISTRICT &

THIS IS AN AGREEMENT entered into between West Sound Utility District, a Washington State Municipal Corporation, hereinafter called "District," and _____, hereinafter called "Contractor."

Pursuant to its resolutions and procedures, the District has determined the Contractor to be the lowest responsible bidder to perform the services hereinafter described. The purpose of this document is to set forth the specific terms of the parties' agreement in writing.

NOW, THEREFORE, in consideration of the foregoing recitals and the promises and covenants of the parties hereinafter set forth, they agree as follows:

1. Services to be performed by Contractor. The services to be performed are identified in the attached plans and specifications, referred to as Attachment "A" which by this reference is incorporated herein. In performing its work, the Contractor shall supply all necessary labor and materials to fully and completely finish the work called for herein.

2. Payment for Services. The total payment from the District to the Contractor for the work to be performed by the Contractor as described herein shall be **the total sum of \$ _____ plus applicable Washington State sales tax.** Payment of this said amount shall be due and owing within forty-five days of the completion of the work by the Contractor and acceptance by the District. Acceptance shall not be unreasonably withheld.

3. Commencement/Completion of Work. **The contractor shall commence its work for the District on or before _____.** **All work called for herein shall be fully completed by the Contractor on or before _____.**

4. Contractor Representations. The Contractor hereby represents and warrants to the District as follows:

A. Bonding Company and License No. The Contractor is fully licensed, bonded, and in good standing with the State of Washington.

- 1) It's Contractor License Number. with Washington State is _____
- 2) It is currently bonded with the following bonding company to do business in the State of Washington
 - a) Bond No. _____.
 - b) This bond was issued on the ____, day of _____, 20__.

3) In addition to the above, the Contractor is required to provide a Performance Bond and Payment in accordance with the Prevailing Wage regulations prior to the commencement of work.

B. Evidence of Insurance. Prior to performing its construction work, the Contractor shall provide the District with written evidence of insurance covering public liability and property damage concerning the work to be performed. If the total amount of services to be performed by the

Contractor exceeds five thousand and 00/100 dollars (\$5,000.00) the coverage limits for liability shall be not less than as set forth on Attachment "B" entitled "Minimum Requirements for Certificates of Insurance" which by this reference is incorporated herein and made a part hereof.

In the event Attachment "B" is applicable hereto, the Contractor shall be obligated to comply with all terms and specifications set forth therein.

C. Hold Harmless Provision. The Contractor shall indemnify, defend, and hold harmless the District, its engineer, agents, and employees from any and all claims, demands, actions, and/or liabilities of every kind and nature as may be made and/or entered against the Districts, its engineer, their agents, and employees by reason of, or arising out of, the acts or omissions of the Contractor, its agents, or employees, including costs and attorney's fees incurred by the Districts and its agents and representatives in investigating and defending against any such claims in the event of failure of the Contractor to so defend as herein required.

D. Prevailing Wages. Concerning the work called for herein, the Contractor agrees to pay hourly wages to its laborers and workers in accordance with Washington law and specifically in accordance with RCW 39.12.020 dealing with the prevailing rates to be paid on public-works projects. The Contractor represents it is fully knowledgeable concerning the terms of RCW 39.12.020. The first invoice cannot be paid until the District has received the approved Intent to Pay Prevailing Wages. Retainage shall be 5% of each invoice. Retainage cannot be released until the Affidavit of Wages Paid is approved by the State and the Department of Revenue has approved the release of funds.

E. Performance of Work. The Contractor shall perform all work in a good, workmanlike and timely fashion. All materials used by the Contractor in its work shall be of a good or superior quality. In performing its work, the Contractor shall also act in accordance with all applicable local, state, and federal laws and regulations.

F. Warranty. The Contractor represents and warrants that all services and materials used by it in its services for the District shall be completely free of defects for a period of time lasting two (2) years from the date of completion. In the event any defects are discovered within the warranty time concerning the Contractor's services or materials used by it, the Contractor shall promptly cure any said defects.

G. Non-assignment of Obligations. The contractor is hereby prohibited from assigning or in any manner transferring its obligations under this contract to any third party or entity. The Contractor shall be personally responsible for performance of all work and obligations placed upon it hereunder. The person in charge of the Contractor's work hereunder shall be _____, and he/she shall make him or herself available to the District representative at all reasonable time for consultation.

H. District Inspection. Prior to commencing its work, the Contractor shall meet with the District representative(s) and these parties shall set forth an inspection schedule to be followed by the District in inspecting the Contractor's work while it is in progress. The contractor shall promptly report to the District, in writing, all errors and omissions it commits in performing the work.

5. Risk of Loss. Until the Contractor's work for the District has been fully completed and accepted by the District, all risk of loss concerning the project shall be borne by the Contractor.

6. Cooperation of Parties. The parties shall strive at all times to cooperate with one another in good faith so the terms and spirit of this agreement may be carried out in a good and timely manner.

7. Legal Action. In the event either party employs an attorney to enforce or defend any claim or cause of action arising out of or relating to this agreement, or any appeal therefrom, then and in

any such event, the prevailing party shall be entitled to recover from the losing party, and the losing party shall pay, all of the prevailing parties reasonable costs and attorney fees therein incurred. The venue and jurisdiction for any such action shall lie with the appropriate court in Kitsap County, Washington.

8. Complete Agreement. This agreement constitutes the full and complete agreement between the parties concerning the matters set forth herein. There are no other agreements, either written or verbal, in existence.

DATED this _____ day of _____, 20_____.

WEST SOUND UTILITY DISTRICT:

Glen R. Screws, General Manager

CONTRACTOR:

ATTACHMENT "B"
MINIMUM REQUIREMENTS FOR
CERTIFICATES OF INSURANCE

COMMERCIAL GENERAL LIABILITY

Bodily Injury	\$500,000 each person \$2,000,000 each occurrence
Property Damage	\$2,000,000 each occurrence \$4,000,000 gen. aggregate
or	
Combined Single Limit	\$2,000,000 each occurrence \$4,000,000 gen. aggregate
Employers Liability	\$2,000,000 each accident \$1,000,000 each employee - disease \$1,000,000 policy limit - disease

AUTOMOBILE LIABILITY

Bodily Injury	\$500,000 each person \$2,000,000 each occurrence
Property Damage	\$2,000,000 each occurrence
or	
Combined Single Limit	\$2,000,000 each occurrence

WORKERS COMPENSATION

Limits	Statutory (show L & I ID #)
--------	--------------------------------

Certificates shall be issued through insurance companies licensed to do business in the State of Washington pursuant to Title 48 RCW and who have a "Best's Insurance Guide" rating of not less than A+VII

Certificates of Insurance must be on file with the Districts prior to the start of any operations within the District.

Public Liability and Property Damage Insurance

General Requirements

1.1 The Contractor shall obtain and keep in force during the term of the contract, Commercial General Liability and Automobile liability insurance policies with insurance companies which have an A.M. Best's rating of A-: VII or better and who are approved by the Insurance Commissioner of the State of Washington pursuant to Title 48 RCW. All insurance coverage required by these specifications shall be written and provided by "occurrence-based" policy forms rather than "claims made" forms.

1.2 Prior to the execution of the contract, the Contractor shall purchase and maintain during the term of this project a Commercial General Liability insurance and Automobile insurance policies meeting the requirements set forth herein. The Contractor shall file with the District **either** a certified copy of all policies **with endorsements attached**, or a certificate of insurance **with endorsements attached** as are necessary to comply with these specifications. Failure of the Contractor to fully comply with the requirements regarding insurance will be considered a material breach of contract and shall be cause for immediate termination of the contract and of any and all District obligations, regarding same.

1.3 The Contractor shall not begin work under the contract or under any special condition until all required insurances have been obtained and until such insurances have been **approved by the District**. The insurance shall provide coverage for the Contractor, the Contractor's agents and employees, subcontractors, and the District. The coverage so provided shall protect against claims from bodily injuries, including accidental death, as well as claims for property damage which may arise from any act or omission of the Contractor, the Contractor's agents and employees, subcontractors, or by anyone directly or indirectly employed by either of them.

1.4 The insurance policies shall specifically name the District, its elected and appointed officials, officers, employees, agents and volunteers as additional insureds with regards to damages and defense of claims arising from: (a) activities performed by or on behalf of the Contractor; (b) products and completed operations of the Contractor, and (c) premises owned, leased or used by the Contractor. The insurance shall be maintained in full force and effect at the Contractor's expense throughout the term of the contract. Products and completed operations coverage shall be maintained for a minimum of three years after completion of the project.

1.5 The District shall be given at least 45 days written notice of any cancellation, nonrenewal, material reduction, or modification of coverage. Such notice shall be by *certified mail* to the District.

1.6 The coverages provided by the Contractor's insurance policies shall be primary to any insurance maintained by the District, except as respects losses attributable to the sole negligence of the District or otherwise limited in accord with the provisions of RCW 4.24.115. Any insurance that might cover this contract that is maintained by the District shall be in excess of the Contractor's insurance and shall not contribute with the Contractor's insurance.

1.7 The Contractor's insurance policies shall protect each insured in the same manner as though a separate policy had been issued to each. The inclusion of more than one insured shall not affect the rights of any insured as respects any claim, suit or judgment made or brought by or for any other insured or by or for any employee of any other insured. However this provision shall not increase the limits of the insurer's liability.

1.8 The General Aggregate provision of the Contractor's insurance policies shall be amended by endorsement to show that the General Aggregate Limit of the policies applies separately to this project.

1.9 The Contractor's insurance policies shall not contain deductibles or self-insured retentions in excess of \$10,000 unless approved by the District.

1.10 The Contractor's insurance policies shall contain a provision that the District has no obligation to report events which might give rise to a claim until a claim has been filed with the District's Board of Commissioners.

1.11 Types and Limits of Insurance Required:

Commercial General Liability

- \$2,000,000 each occurrence Bodily Injury and Property Damage liability
- \$2,000,000 annual aggregate
- Employees and volunteers as Additional Insureds
- Premises and operations
- Broad form property damage including underground, explosion and collapse hazards (XCU)
- Products completed operations (shall be maintained for at least three years after completion.)
- Blanket contractual
- Subcontractors
- Personal injury with employee exclusion deleted
- Employers liability (Stop gap)

Automobile Liability

- \$2,000,000 per accident bodily injury and property damage liability, including
- Any owned automobile
- Hired automobiles
- Non-owned automobile

Umbrella Liability (applicable to both the Commercial General and Auto Liability coverage and employers liability, provided this requirement may be satisfied through the Contractor's primary commercial general and auto liability coverage, or any combination thereof.

- \$2,000,000 per occurrence
- \$2,000,000 aggregate

1.12 Providing coverages in the stated amounts shall not be construed to relieve the Contractor from liability in excess of such limits.

1.13 The Contractor shall have its insurance agent/representative complete the Insurance Coverage Questionnaire contained in the proposal and attach it to the certificate of insurance for District's approval.

1.14 The Contractor shall maintain Workers Compensation insurance and/or Longshore and Harbor Workers insurance (or Jones Act coverage for all employees eligible for same) as required by state or federal statute for all of the Contractor's employees to be engaged in work on the project under this contract and, in case any such work is sublet, the Contractor shall require the subcontractor similarly to provide workers compensation insurance and/or longshore and harbor workers insurance (or Jones Act coverage) for all of the subcontractor's employees to be engaged in such work. The Contractor's Department of Labor & Industries account number shall be noted on the certificate of insurance. In the event any class of employees engaged in the work under this contract is not covered under Workers Compensation insurance or Longshore and Harbor Workers insurance (or Jones Act coverage) as required by state and federal statute, the Contractor shall maintain and cause each subcontractor to maintain, Employers Liability insurance for limits of at least \$1,000,000 for each employee for disease or accident, and shall furnish the District with satisfactory evidence of such.

1.15 The Contractor shall be solely and completely responsible for safety and safety conditions on the job site, including the safety of all persons and property during performance of the work. The services of District employees or the engineer's personnel in conducting construction review of the Contractor's performance is not intended to include review of the adequacy of the Contractor's work methods, equipment, bracing, scaffolding, or trenching, or safety measures in, on, or near the construction site. The Contractor shall provide safe access for the District and its inspectors to adequately inspect the quality of work and the conformance with project specifications.

1.16 The Contractor shall be solely and completely responsible to perform all work and furnish all materials in strict compliance with all applicable state, city, county and federal laws, regulations, ordinances, orders and codes. The Contractor's attention is directed to the requirements of the Washington Industrial Safety and Health Act (WISHA), Chapter 49.17 RCW.

1.17 The District will make no progress payments until the Contractor has fully complied with this section. This remedy is not exclusive and the District may take such other action as is available under other provisions of this contract, or otherwise in law.

1.18 The contractual coverage of the Contractor's policy shall be sufficiently broad enough to insure the provisions of the **HOLD HARMLESS AND INDEMNIFICATION AGREEMENT** of this contract.

1.19 Nothing contained in these insurance requirements shall be construed as limiting the extent of the Contractor's responsibility for payment of damages resulting from the Contractor's operations under this contract.

SUBCONTRACTORS

The Contractor shall ensure that each subcontractor of every tier obtains and maintains at a minimum the insurance coverages listed above. Upon request of the District, the Contractor shall provide evidence of such insurance.

EVIDENCE OF INSURANCE

The Contractor shall provide to the District a certificate(s) of insurance and endorsements for each policy of insurance meeting the requirements set forth herein when the Contractor delivers the signed contract to the District for the work. The certificate and endorsements shall conform to the following requirements:

1. An Acord certificate or a form determined by the District to be equivalent. The certificate or an endorsement form shall indicate the Contractor's insurance is primary and non-contributory.
2. The Contractor shall obtain endorsement forms CG 20 10 10 01 and CG 20 37 10 01, or the equivalent of each, naming the District and all other parties listed herein as Additional Insured(s) and providing the policy number. If the Contractor is unsuccessful in securing these endorsements after exerting commercially reasonable efforts, the Contractor shall obtain other endorsements providing equivalent coverage to the Additional Insured, subject to the review and approval of such other endorsement forms by the District. A statement of additional insured status on an Acord certificate of insurance shall not satisfy this requirement. Commercially reasonable efforts shall be evidenced by a signed statement by the Contractor's insurance broker certifying the endorsement forms required by the District are not available and the endorsements submitted provide equivalent coverage to the Additional Insured.
3. Any other amendatory endorsements to show the coverage required herein.

NOTE: THIS QUESTIONNAIRE MUST BE COMPLETED AND ATTACHED TO CERTIFICATE OF INSURANCE AND POLICY ENDORSEMENT.

Insurance Coverage Questionnaire

For _____
(Name of Insured)

Project Number _____

Project Owner _____

Are the following coverages &/or conditions in effect?		
	Yes	No
The Policy form is ISO Commercial General Liability (CGL) form CG 00 01 of CG 00 02 (circle one). If No, attach a copy of the policy with required coverages clearly identified.		
(CGL) Ongoing Operations coverage (similar to CG 20 10 10 01, CG 2010 07 04, or equivalent)		
(CGL) Products and Completed operations coverage (similar to CG 20 37 07 04, CG 20 37 07 04, or equivalent)		
Personal Injury Liability Coverage. (with employee exclusion deleted)		
Broad Form Property Damage with X, C, U Hazards included		
Blanket Contractual Liability coverage applying to this contract		
Employers Liability - Stop Gap		

Deductibles
or SIRs: GL _____ AL _____ Excess _____

Insurer' Best Rating GL _____ AL _____ Excess _____

This Questionnaire is issued as a matter of information. This questionnaire is not an insurance policy and does not amend, extend or alter the coverage afforded by the policies indicated on the attached Certificate of Insurance.

Agency/Broker

Completed by (type)

Address

Completed by (Signature)

Name of Person to contact

Telephone Number

PERFORMANCE AND PAYMENT BOND

KNOW ALL MEN BY THESE PRESENTS: THAT whereas West Sound Utility District, Port Orchard, Washington a municipal corporation has awarded to:

(Contractor)

hereinafter designated as the "Principal", a contract for work items, which contract consists of the Proposal/Agreement, together with the Contract Documents, Specifications, Addenda and Plans, all as hereto attached and made a part hereof, and more particularly described as:

and whereas said principal is required under the terms of said contract to furnish a bond for the faithful performance of said contract:

NOW, THEREFORE, we the Principal and _____, a corporation, organized and existing under and by virtue of the laws of the State of Washington, and duly authorized to do business in the State of Washington as surety, are firmly bound unto West Sound Utility District in the sum of _____ lawful money of the United States, for the payment of which sum well and truly to be made, we bind ourselves, our heirs, executors, administrators, successors and assigns, jointly and severally, firmly by these presents.

THE CONDITION OF THIS OBLIGATION IS SUCH, that if the above bonded principal, his or its heirs, executors, administrators, successors or assigns, shall in all things stand to and abide by, and well and truly keep and perform the covenants, conditions and agreements in said contract, and shall faithfully perform all the provisions of such contract, and shall also well and truly perform and fulfill all the undertakings, covenants, terms, conditions and agreements of any and all duly authorized modifications of said contract that may hereafter be made, at the time and in the manner therein specified; and shall pay all laborers, mechanics, subcontractors and materialmen, and all persons who shall supply such person or persons, or subcontractors, with provisions and supplies for the carrying on of such work on his or their parts; and shall indemnify and save harmless the Owner's Engineer, its officers and agents, from any loss or damage occasioned to any person or property by reason of any careless or negligence on the part of said principal, or any subcontractor, in the performance of said contract or any modifications thereof; and shall further indemnify and save harmless West Sound Utility District, its officers and agents, from any damage or expense by reason of failure of performance as required by said contract, or any modifications thereof, or from defects appearing or developing in the material or workmanship provided or performed under said contract within a period of two years after acceptance thereof by West Sound Utility District, then this obligation shall become null and void, otherwise it shall be and remain in full force and effect.

And the said surety, for value received, hereby further stipulates and agrees that no change, extension of time, alteration or addition to the terms of the contract or to the work to be performed thereunder or the specifications accompanying the same shall in any way affect its obligation on this bond, and it does hereby waive notice of any change, extension of time, alternations or additions to the terms of the contract or the work or to the specifications.

IN WITNESS THEREOF, the said Principal and the said surety caused this bond and three (3) counterparts thereof to be signed and sealed by their duly authorized officers, this _____ day of _____, 20__.

Principal

By _____

Title _____

ATTEST (If Corporation)

WITNESSES (If Individual or Partnership)

CORPORATE SEAL

By _____

Title _____

Address of local office and agent of Surety Company is:

NON-COLLUSION AFFIDAVIT
(Contractor/Proposer)

State of Washington)
) ss
County of Kitsap)

The undersigned, being duly sworn, deposes and says that the person, firm, association, co-partnership or corporation herein named, has not, either directly or indirectly, entered into any agreement, participated in any collusion, or otherwise taken any action in restraint of free competitive bidding in the preparation and submission of a proposal to WSUD for consideration in the award of a Contract on the Project described as follows: _____
_____.

Name of Firm (Contractor)

Authorized Signature

Title
(Affix Corporate Seal)

STATE OF WASHINGTON)
) ss
COUNTY OF KITSAP)

I certify that I know or have satisfactory evidence that _____, is the person who appeared before me, and said person acknowledged he signed this instrument, and on oath stated he was authorized to execute it on behalf of _____, a Washington _____; and he acknowledged it as the authorized signer of said _____, to be the free and voluntary act of such _____ for the uses and purposes mentioned in the instrument.

Dated: _____

Print Name: _____
NOTARY PUBLIC in and for the State of
Washington, residing in _____

My Commission Expires: _____

**NON-COLLUSION AFFIDAVIT
(Subcontractor)**

State of Washington)
) ss
County of Kitsap)

The undersigned, being duly sworn, deposes and says that the person, firm, association, co-partnership or corporation herein named, has not, either directly or indirectly, entered into any agreement, participated in any collusion, or otherwise taken any action in restraint of free competitive bidding in the preparation and submission of a proposal to subcontract work in connection with the Project as specified in the proposal submitted by

_____.

Name of Firm (Subcontractor)

Authorized Signature

Title
(Affix Corporate Seal)

STATE OF WASHINGTON)
) ss
COUNTY OF KITSAP)

I certify that I know or have satisfactory evidence that _____, is the person who appeared before me, and said person acknowledged he signed this instrument, and on oath stated he was authorized to execute it on behalf of _____, a Washington _____; and he acknowledged it as the authorized signer of said _____, to be the free and voluntary act of such _____ for the uses and purposes mentioned in the instrument.

Dated: _____

Print Name: _____
NOTARY PUBLIC in and for the State of
Washington, residing in _____

My Commission Expires: _____

**WEST SOUND UTILITY DISTRICT
BID BOND FORM**

Herewith find deposit in the form of a certified check, cashier's check, or cash in the amount of \$ _____ which is **not less than five percent (5%) of the total bid.**

Sign Here: _____

BID BOND

Know all men by these presents, that we _____ as Principal and _____ as Surety, are held and firmly bound unto WSUD, as obligee in the penal sum of _____ dollars, for the payment of which the principal and the surety binds themselves, their heirs, executors, administrators, successors and assigns, jointly and severally, by these presents.

The condition of the obligation is such that if the obligee shall make any award to the principal for _____, according to the terms of the proposal or bid made by the principal therefore, and the principal shall duly make and enter into a contract with the obligee in accordance with the terms of said proposal or bid award and shall give bond for faithful performance thereof, with surety or sureties approved by the obligee; or if the principal shall, in case of failure to do so, pay and forfeit to the obligee the penal amount of the deposit specified in the call for bids, then this obligation shall be null and void; otherwise it shall be and remain in full force and effect and the surety shall forthwith pay and forfeit to the obligee, as penalty and liquidated damages the amount of this bond.

Signed, sealed, and dated this _____ day of _____, 20_____.

Principal: _____

Surety: _____

Return of deposit in the amount of
\$ _____

Date: _____ By: _____

**WEST SOUND UTILITY DISTRICT
RESOLUTION 1086-23**

**A RESOLUTION OF THE
WEST SOUND UTILITY DISTRICT BOARD OF COMMISSIONERS
AUTHORIZING A PROFESSIONAL SERVICES AGREEMENT
WITH
BHC CONSULTANTS ENGINEERING
FOR ON-CALL SERVICES**

WHEREAS, The District allocates funding within the SKWRF, Water, and Sewer departments' annual budgets for Engineering Services; and

WHEREAS, the consultant has prepared a professional services agreement for on-call professional engineering, consulting, and related services in connection with district projects and needs not to exceed \$50,000 annually for such on-call services; **NOW, THEREFORE**,

THE BOARD OF COMMISSIONERS OF WEST SOUND UTILITY DISTRICT HEREBY RESOLVES:

Section 1. The Board of Commissioners hereby approves the attached professional services agreement (Exhibit "A") for on-call professional engineering, consulting, and related services with BHC Consultants. The Board further authorizes the General Manager to sign the attached Professional Services Agreement with BHC Consultants.

APPROVED and ADOPTED by the Board of Commissioners of West Sound Utility District at a Board meeting scheduled on June 7, 2023.

WEST SOUND UTILITY DISTRICT
Kitsap County, Washington

Susan Way
Chairperson

James J. Hart
Vice Chairperson

Jerry Lundberg
Secretary

PROFESSIONAL SERVICES AGREEMENT

THIS PROFESSIONAL SERVICES AGREEMENT, which is referred to hereinafter as “this Agreement”, is made and entered by and between BHC Consultants, LLC (“BHC”) and West Sound Utility District (“CLIENT”) with offices at 2924 SE Lund Avenue, Port Orchard, WA, 98366 and is effective as of the last date written below. BHC and CLIENT are sometimes referred to in this Agreement individually as “party” and together as “parties”.

Project: General On-Call Engineering Services

Scope of Services

The scope of services to be performed, and the schedule and compensation for performing those services, shall be as described on Exhibit “A”, attached, hereby incorporated into this Agreement. The GENERAL CONDITIONS stated below are part of this Agreement.

In witness whereof, the parties have made and executed this Agreement.

BHC Consultants, LLC

West Sound Utility District

(Client)

By: _____

By: _____

Title: _____

Title: _____

Signature: _____

Signature: _____

Date: _____

Date: _____

GENERAL CONDITIONS

Independent Contractor: BHC is an independent contractor and is not an agent or employee of CLIENT.

Assignment: Neither party may assign this Agreement or any rights or responsibilities under it, whether during performance or after performance, without first obtaining the other party’s written consent.

Compliance with Laws, Permits and Licenses: BHC shall comply with responsible interpretations of applicable laws, regulations, ordinances and permits that are in effect at the time of performance.

Taxes: BHC shall comply with applicable federal, state and local tax laws.

Provision of Documents: CLIENT shall provide BHC with pertinent information and documents concerning the CLIENT’s requirements for the Project. This includes drawings, specifications, schedules and other information prepared by or available to CLIENT pertinent to the services. BHC is entitled to rely upon the completeness and accuracy of the documents and information provided by CLIENT.

Authorization: BHC shall begin performance upon receipt of a copy of this Agreement bearing the CLIENT’s signature unless stated otherwise in writing.

Changes and Additional Services: CLIENT and BHC may agree to modify the scope of services and may agree to the performance of additional services for additional compensation. All changes shall be in writing and shall take effect only when signed by both parties.

Invoicing: BHC shall submit monthly progress billings to CLIENT. If services are performed on a lump sum fee basis, progress billings shall be on a percent-complete basis. If services are performed on a time-and-materials basis, progress billings shall itemize actual hours worked, equipment, outside services and a brief description of the services provided; hourly rates shall be in accordance with the current BHC Rate Schedule.

Payment: Payment to BHC for services performed and reimbursable costs incurred shall be made within 30 days of receipt of invoice. All payments shall be delivered to: BHC Consultants, LLC, 1601 Fifth Avenue Suite 500, Seattle WA 98101.

Termination for Convenience: CLIENT, for its convenience, may terminate this Agreement in whole or in part at any time by written notice, which shall state the extent and effective date of such termination. CLIENT shall reimburse BHC for reasonable costs necessarily incurred by BHC following receipt of the notice of termination.

PROFESSIONAL SERVICES AGREEMENT

Termination for Default: Either party may terminate this Agreement if the other party substantially fails to meet its obligations under this Agreement. Said termination will become effective upon five business days' written notice unless the defaulting party cures the default within that five-day period or provides satisfactory evidence to the non-defaulting party within the five-day period that such default will be cured within a satisfactory time.

Records: BHC shall maintain all records pertaining to the Project for a period of not less than two years. These shall be available to CLIENT for its review upon reasonable notice.

Confidentiality: BHC will not disclose any documents, reports, disclosures, plans or other information that CLIENT identifies as proprietary or confidential to any third party except as necessary to perform services pursuant to this Agreement or except as required by law.

Ownership of Documents: All documents prepared by BHC pursuant to this Agreement are instruments of service intended for use solely with respect to this Project. These instruments of service shall become the property of CLIENT upon CLIENT's full performance of its payment obligations under this Agreement. Any use of the instruments of service on a different project, or on this project following a termination of this Agreement when BHC is not in default, by CLIENT or others shall be without liability on the part of BHC or its employees or subconsultants.

Insurance:

A. BHC shall maintain continuously during the life of this Agreement the following minimum insurance requirements:

1. Worker's Compensation Insurance per Washington statutes.
2. Commercial General Liability with limits of not less than \$1,000,000 applicable to bodily injury, sickness, or death in any one occurrence or in the aggregate and not less than \$1,000,000 for loss of, or damage to, property in any one occurrence or in the aggregate.
3. Automobile Liability covering all owned, non-owned, or hired vehicles used by BHC with combined single limits of not less than \$1,000,000.
4. Professional Liability Insurance in the amount of \$2,000,000 per claim and annual aggregate covering BHC's negligent professional acts, errors, or omissions.

BHC will provide CLIENT with evidence of the above-stated coverages upon written request received.

B. CLIENT will carry Commercial General Liability Insurance with limits of not less than \$1,000,000 per occurrence and policy aggregate. CLIENT will carry, or will require the Contractor to carry, builder's risk insurance for the full replacement value of the completed Project.

C. Except to the extent that it impairs coverage, each party waives all claims for recovery of costs, losses and damages from the other to the extent covered by insurance carried by or for the benefit of the party incurring the costs, losses or damages.

Construction: Only CLIENT has the right to reject or stop work of its contractors or agents. BHC will notify CLIENT of non-conforming work performed by the CLIENT's contractor(s) coming to the attention of BHC, but BHC is not responsible for inspecting the construction work or for performing exhaustive observations of the construction work. BHC is not responsible for, and does not have control or charge of, the specific means, methods, techniques, sequences or procedures employed by the CLIENT's contractor(s) or for jobsite safety or jobsite safety programs. BHC is not responsible for any failure on the part of the contractor(s) to perform work in accordance with the plans and specifications.

Laws: This Agreement shall be governed by and interpreted in accordance with the internal laws of the State of Washington.

Force Majeure: BHC shall not be liable for failure to perform when its performance is hindered or prevented by an occurrence beyond the reasonable control of BHC.

No Third Party Rights: All duties and responsibilities undertaken pursuant to this Agreement are for the sole and exclusive benefit of the parties hereto. There shall be no third party beneficiaries of this Agreement.

No Consequential Damages: BHC and CLIENT waive all claims for consequential damages against each other for claims, disputes, and causes of action arising out of or related to this Agreement and/or the Project.

Dispute Resolution: CLIENT and BHC agree that all disputes between them arising out of or related to this Agreement, or the breach or alleged breach of this Agreement, that cannot be resolved by direct discussions shall be submitted to and considered in nonbinding mediation before either party may commence litigation. Unless the parties subsequently agree otherwise, the mediation shall be administered by the American Arbitration Association in Seattle acting under its Construction Industry Mediation Rules.

Entire Agreement: This Agreement, including Exhibits incorporated herein by reference, states all of the terms of the agreement between the parties respecting its subject matter and supersedes all prior and contemporaneous written and unwritten negotiations, proposals, representations, commitments and agreements. This Agreement may be modified only by way of an instrument signed by authorized representatives of both parties.



1601 Fifth Avenue, Suite 500
Seattle, Washington 98101

p. 206.505.3400
f. 206.505.3406

Exhibit A

May 26, 2023

Mr. Randy Screws
West Sound Utility District
2924 SE Lund Ave
Port Orchard, Washington 98366

Re: *General On-Call Engineering Services*
West Sound Utility District

Dear Randy:

BHC is pleased to provide this scope of services for General On-Call Engineering Services to West Sound Utility District (WSUD) per your request. We look forward to continuing the strong relationship that has been established and addressing your future engineering and planning needs.

Under an On-Call Engineering Contact, BHC may perform professional engineering, surveying, planning, and management services as requested during the term of this Agreement, or as such Agreement may be extended, including the following:

- Development of studies, plans and reports.
- Analysis of utility rates and infrastructure funds.
- Design plans and specifications and contract documents.
- Assistance with grant and loan funding applications and prospectuses.
- Hydraulic modeling associated with utility systems and utility improvements.
- Surveying tasks for right-of-way, easements, property boundaries, and subdivision of property.
- Project cost estimates (opinions of cost).
- Coordination with the Washington Department of Ecology or the Department of Health.
- Emergency projects as required by WSUD.
- Miscellaneous engineering and surveying tasks as requested.

When requested by WSUD, scopes and budgets will be prepared for specific task orders. Deliverables to WSUD will depend on the activity being performed and will include letters, reports, memos, and design documents (drawings, specifications and cost estimates).

On-Call Engineering Services will be performed according to the attached 2023 Rate Schedule. Invoices will be provided on a monthly basis.

BHC would be happy to provide a Statement of Qualifications to WSUD. Alternatively, if WSUD is a member of MRSC, BHC's SOQ can be found on MRSC's website under the consultant rosters.

West Sound Utility District
General On-Call Services
May 26, 2023
Page 2



If this scope for General On-Call Engineering Services is acceptable to WSUD, please indicate your approval by signing the attached standard BHC Professional Services Agreement. Alternatively, if you would like to use a WSUD standard contract, that would be fine with us.

Thanks again for this opportunity to work with WSUD on your important project needs. If you have any questions or need anything further, please feel free to call me at 206-979-2837.

Sincerely,
BHC Consultants, LLC

A handwritten signature in black ink, appearing to read 'James Gross', with a long horizontal flourish extending to the right.

James Gross, P.E.
President

2023 Schedule of Charges

Billing Title	Hourly Billing Rates
Principal Engineer	\$270 - \$300
Senior Structural Engineer	\$260 - \$280
Senior Electrical Engineer	\$255 - \$280
Project Manager	\$220 - \$295
Senior Engineer	\$220 - \$295
Project Engineer	\$150 - \$250
Staff Engineer	\$125 - \$165
Planning Manager	\$175 - \$200
Senior Planner	\$175 - \$190
Planner	\$115 - \$130
GIS Specialist*	\$125 - \$165
Field Inspector & Building Inspectors*	\$140 - \$180
Building Code Compliance Review	\$150 - \$225
CAD Manager*	\$160 - \$205
Draftsperson*	\$130 - \$165
Project Administrator*	\$130 - \$165
Project Assistant/Word Processor*	\$120 - \$145

Professional Reimbursement:

The hourly billing rates include the cost of salaries of the BHC employees, plus paid sick and safe leave, vacation, holiday, other fringe benefits, indirect overhead and fee. All employees classified as “non-exempt” (billing category denoted with *) by the U.S. Department of Labor will be compensated at 1-1/2 times salary for overtime hours, as per State and Federal wage and hour laws. Billing rates will be calculated accordingly for these overtime hours.

Direct Expenses/Subconsultants:

Reimbursement for direct expenses and subconsultants incurred in connection with the work, will be at cost plus ten percent. Mileage will be expensed at the current IRS rate.

The foregoing Schedule of Charges is incorporated into the agreement for the services provided, effective January 1, 2023 through December 31, 2023, and will be adjusted thereafter.

WEST SOUND UTILITY DISTRICT

RESOLUTION 1087-23

**A RESOLUTION OF THE BOARD OF COMMISSIONERS
OF
WEST SOUND UTILITY DISTRICT
ACCEPTING THE DEVELOPER'S EXTENSION CONTRACT FOR
FOR SEWER AND WATER UTILITIES
INSIDE AND OUTSIDE OF THE FOUR SEASONS PLAT.**

WHEREAS, Mr. Jason Hancock, Authorized Agent for Lennar NW, Inc. (Developer), entered into a Development Extension Agreement on May 2, 2022, for extension of water, sewer extension, and services for the Four Seasons Plat located on Warner Avenue SE consisting of a thirty-five (35) lot plat; and

WHEREAS, the Developer has completed construction of the water and sewer systems in accordance with the standards of the District and approved by the District's Operations staff; and

WHEREAS, the water and sewer system to be conveyed to the District consists of the items and quantities identified per the attached (Exhibit A) which includes the Water System Construction Cost Worksheet and the Sewer System Construction Cost Worksheet; and

WHEREAS, the water system for an asset value of \$320,485.00 and the sewer system for an asset value of \$528,325.19 shall be conveyed to the District upon the acceptance of the water, and sewer system services by the District's Board of Commissioners; **NOW, THEREFORE**,

THE BOARD OF COMMISSIONERS OF WEST SOUND UTILITY DISTRICT HEREBY RESOLVES:

Section 1. West Sound Utility District accepts the improvements of the water and sewer extensions and services for the Four Seasons Plat located on Warner Avenue SE consisting of a thirty-five (35) lot plat. The Board further authorizes the District's General Manager to sign the conveyance documents (Exhibit B).

APPROVED and ADOPTED by the Board of Commissioners of West Sound Utility District at a regularly scheduled meeting on June 7, 2023.

WEST SOUND UTILITY DISTRICT
Kitsap County, Washington

Susan Way
Chairperson

James J. Hart
Vice Chairperson

Jerry Lundberg
Secretary



2924 SE Lund Avenue, Port Orchard, WA 98366
 (360) 876-2545 • Fax (360) 874-5030
 www.customerservice @wsud.us

SEWER SYSTEM CONSTRUCTION COST WORKSHEET

Project Name: Four Seasons

Submitted by: _____

SEWER MAINS

GRAVITY MAINS	FEET		COST	WSUD ASSETS (INTERNAL USE)
8"	2,425		\$284,388.64	<i>284,388.64</i>
10"				
12"				
15"				
CLEANOUT ASSY.	QUANTITY			
6"	35		\$29,750.00	<i>29,750.00</i>
8"	3		\$1,215.00	<i>1,215.00</i>
CLEANOUT BOXES	38		INC	
FORCE MAINS (HDPE)	QUANTITY			
2"	0		0	
4"	0		0	
6"	0		0	
8"	0		0	
	QUANTITY			
TAPS	0		0	
VALVES	QUANTITY			
2"	0		0	
4"	0		0	
6"	0		0	
8"	0		0	
	QUANTITY			
VALVE BOXES	0		0	
TESTING	2		\$20,428.60	<i>20,428.60</i>
FLUSH/TV	1		\$5,318.20	
TRACE WIRE			inc	

SEWER SYSTEM CONSTRUCTION COST WORKSHEET

SEWER STUBS

SEWER STUBS	FEET		COST	
4"				
6"	35		\$82,250.00	82,250.00
FITTINGS				
TOTAL SEWER CONNECTIONS	35		\$12,971.00	12,971.00
CLEANOUT BOXES	28		INC	
GRINDER STUB & VALVES	0		0	
GRINDER VALVE BOX	0		0	
GRINDER DISCHARGE LINE	FEET			
1 1/4" (HDPE)	0		0	
FUSION FITTINGS	0		0	
	QUANTITY			
E-ONE STATIONS	0		0	
TESTING	0		0	

MANHOLES

	QUANTITY		COST	
MANHOLE STRUCTURES	15		\$97,321.95	97,321.95
LIDS			INC	
RISER RINGS			INC	
CORE DRILLING			INC	
TESTING			INC	

MOBILIZATION

TOTAL MOBE COST	1		\$21,000.00	
-----------------	---	--	-------------	--

TOTAL COST:

\$554,643.39	528,325.19
--------------	------------

IT IS THE RESPONSIBILITY OF THE DEVELOPER TO INCLUDE THE MATERIALS AND THE COSTS OF MATERIALS THAT ARE NOT LISTED ON THIS WORKSHEET

WATER SYSTEM CONSTRUCTION COST WORKSHEET

Project Name: Four Seasons

Submitted by: _____

WATER MAINS				
MAINS	FEET		COST	WSUD ASSETS (INTERNAL USE)
2"				
4"	124		INC	
6"				
8"	1590		\$128,743.92	128,743.92
12"				
FITTINGS			INC	
TESTING	3		8,463.85	8,463.85
BLOCKING			INC	
VALVES	QUANTITY			
2"	1		INC	
4"	2		\$1,417.00	1,417.00
6"				
8"	12		\$22,557.10	22,557.10
12"				
	QUANTITY			
VALVE BOXES			INC	
TRACE WIRE				
	QUANTITY			
BLOW OFF ASSEMBLY	2		\$5,600	5,600
	QUANTITY			
AIR VAC ASSEMBLY				
WET TAPS	QUANTITY	SIZE		
	2	(1)4" & (1)8"	\$21,462.10	21,462.10
	QUANTITY	SIZE		
PRV STATIONS				

WATER SYSTEM CONSTRUCTION COST WORKSHEET

HYDRANTS				
	QUANTITY			
HYDRANTS	4		\$25,023.58	<i>25,023.58</i>
	FEET			
6" PIPE			INC	
VALVES			INC	
VALVE BOXES			INC	
TEES'			INC	
STORTZ ADAPTER			INC	
FITTINGS			INC	
SERVICES				
	FEET			
POLY PIPE				
2"	1		\$2,528.80	<i>2,528.80</i>
1 1/2"				
1"	44		\$104,688.65	<i>104,688.65</i>
3/4"				
	QUANTITY			
TAPS			INC	
SADDLES			INC	
CORP STOPS			INC	
SETTERS				
2"			INC	
1 1/2"			INC	
1"			INC	
3/4"			INC	
METER BOXES			INC	
MOBILIZATION				
TOTAL MOBE COST			\$15,000.00	<i>_____</i>
			TOTAL WATER COST	
			\$335,485.00	<i>320,485.00</i>
IT IS THE RESPONSIBILITY OF THE DEVELOPER TO INCLUDE THE MATERIALS AND THE COSTS OF MATERIALS THAT ARE NOT LISTED ON THIS WORKSHEET				

West Sound Utility District recommends that you retain a copy of this completed form for your personal records
(Sewer System Construction Worksheet)



**DEVELOPER EXTENSION CONTRACT
FOUR SEASONS**

JUNE 7, 2023





2924 SE Lund Avenue, Port Orchard, WA 98366
(360) 876-2545 • Fax (360) 874-5030
www.customerservice@wsud.us

BILL OF SALE AND CONVEYANCE

Project Name: Four Seasons

The Developer, namely, Lennar Northwest LLC, for and in consideration of the mutual promises contained in the Contract, hereby grants, bargains, sells, conveys, delivers, and warrants to West Sound Utility District, the following described personal property and real property located in Kitsap County, Washington, to wit:

1. (Itemized description of Developer Improvements to be conveyed):

See attached Exhibit A - Water System Construction Cost Worksheet and
Exhibit B - Sewer System Construction Cost Worksheet

2. Legal description and tax parcel numbers of all real property and easements to be conveyed:

SW/SE 30-24N-2E
Parcel # 302402-4-048-2006

Together with any easements or other existing interests in real property incident thereto and necessary for the ownership, operation, and maintenance of the Developer Improvement.

The Developer covenants and warrants to the District, its successors, and assigns, that the Developer is the owner of the said real and personal property and has good right and authority to sell the same, and that it will and does hereby warrant and agree to defend the sale thereof to the District, its successors, and its assigns against all and every person and/or entity claiming the same, whether said claim is with or without merit.

The Developer further warrants the Developer Improvement is fit for purposes intended, i.e., for use as a water collection and conveyance system or wastewater distribution system, and that the same has been constructed in accordance with this Contract.

The Developer further covenants, warrants, and agrees to repair, correct and bear the cost of any defect concerning any work or material associated with construction of the Developer Improvement which may arise for a two year period from the District's date of acceptance of this Bill of Sale, and to hold the District harmless from any and all costs arising in connection therewith or any and all liability of every kind and nature arising therefrom. When corrections of defects occurring within the warranty period are made, the Developer shall further warrant corrected work for two years after acceptance of the corrected work by the District.

Dated this _____ of May _____, 2023.

Developer by: 

Print Name: Jason Hancock

State Title: Authorized Agent

Its duly authorized representative for entry into this Exhibit

Address 33455 6th Avenue S, Unit 1-B, Federal Way, WA 98003

Contact telephone numbers: (253) 590-2200

Accepted by WEST SOUND UTILITY DISTRICT on this _____ day of _____, 20____
pursuant to the District Resolution hereinafter set forth.

Resolution No. _____

WEST SOUND UTILITY DISTRICT

By _____
General Manager

WEST SOUND UTILITY DISTRICT

RESOLUTION 1087-23

**A RESOLUTION OF THE BOARD OF COMMISSIONERS
OF WEST SOUND UTILITY DISTRICT
ACCEPTING THE DEVELOPER'S EXTENSION CONTRACT FOR
FOR SEWER AND WATER UTILITIES INSIDE AND OUTSIDE THE
PAYSENO LANE PHASE II MULTI FAMILY APARTMENTS**

WHEREAS, Mr. Dave Burk, Owner of Payseno Lane II, LLC., (Developer), entered into a Development Extension Agreement on July 18, 2022, for extension of water, sewer, and services for Phase II of the Payseno Lane Multi Family Apartments; and

WHEREAS, the Developer has completed construction of the water and sewer systems in accordance with the standards of the District and approved by the District's Operations staff; and

WHEREAS, the water and sewer system to be conveyed to the District consists of the items and quantities identified per the attached (Exhibit A) which includes the Water System Construction Cost Worksheet and the Sewer System Construction Cost Worksheet; and

WHEREAS, the water system for an asset value of \$320,485.00 and the sewer system for an asset value of \$528,325.19 shall be conveyed to the District upon the acceptance of the water, and sewer system services by the District's Board of Commissioners; **NOW, THEREFORE**,

THE BOARD OF COMMISSIONERS OF WEST SOUND UTILITY DISTRICT HEREBY RESOLVES:

Section 1. West Sound Utility District accepts the improvements of the water and sewer extensions and services for the Phase II portion of the Payseno Lane Multi Family Apartments. The Board further authorizes the District's General Manager to sign the conveyance documents (Exhibit B).

APPROVED and ADOPTED by the Board of Commissioners of West Sound Utility District at a regularly scheduled meeting on June 7, 2023.

WEST SOUND UTILITY DISTRICT
Kitsap County, Washington

Susan Way
Chairperson

James J. Hart
Vice Chairperson

Jerry Lundberg
Secretary



2924 SE Lund Avenue, Port Orchard, WA 98366
 (360) 876-2545 • Fax (360) 874-5030
www.customerservice@wsud.us

WATER SYSTEM CONSTRUCTION COST WORKSHEET

Project Name: Payseno Lane II

Submitted by: Pat Hall Construction, Inc.

WATER MAINS				
MAINS	FEET		COST	WSUD ASSETS (INTERNAL USE)
2"				
4"				
6"				
8"	322		16700.00	16,700 ⁰⁰
12"				
FITTINGS				
TESTING	322		250.00	250 ⁰⁰
BLOCKING	3		450.00	450 ⁰⁰
VALVES				
	QUANTITY			
2"				
4"	1		640.00	640 ⁰⁰
6"				
8"	1		975.00	975 ⁰⁰
12"				
	QUANTITY			
VALVE BOXES	4		800.00	800 ⁰⁰
TRACE WIRE	322		65.00	65 ⁰⁰
	QUANTITY			
BLOW OFF ASSEMBLY				
	QUANTITY			
AIR VAC ASSEMBLY				
WET TAPS				
	QUANTITY	SIZE		
	1	8	3250.00	3,250 ⁰⁰
	QUANTITY	SIZE		
PRV STATIONS				

WATER SYSTEM CONSTRUCTION COST WORKSHEET

HYDRANTS				
	QUANTITY			
HYDRANTS	2		1800.00	<i>1800⁰⁰</i>
	FEET			
6" PIPE	20		1100.00	<i>1100⁰⁰</i>
VALVES	2		1400.00	<i>1400⁰⁰</i>
VALVE BOXES	2		400.00	<i>400⁰⁰</i>
TEES'				
STORTZ ADAPTER	2		200.00	<i>200⁰⁰</i>
FITTINGS	2		450.00	<i>450⁰⁰</i>
SERVICES				
POLY PIPE	FEET			
2"	125		650.00	<i>650⁰⁰</i>
1 1/2"				
1"				
3/4"				
	QUANTITY			
TAPS	3		450.00	<i>450⁰⁰</i>
SADDLES	3		120.00	<i>120⁰⁰</i>
CORP STOPS	3		450.00	<i>450⁰⁰</i>
SETTERS				
2"	3		2100.00	<i>2100⁰⁰</i>
1 1/2"				
1"				
3/4"				
METER BOXES	3		450.00	<i>450⁰⁰</i>
MOBILIZATION				
TOTAL MOBE COST			0	
			TOTAL WATER COST	
			32,700.00	<i>32,700⁰⁰</i>

IT IS THE RESPONSIBILITY OF THE DEVELOPER TO INCLUDE THE MATERIALS AND THE COSTS OF MATERIALS THAT ARE NOT LISTED ON THIS WORKSHEET



**DEVELOPER EXTENSION CONTRACT
PAYSENO LANE II
JUNE 7, 2023**





2924 SE Lund Avenue, Port Orchard, WA 98366

(360) 876-2545 • Fax (360) 874-5030

www.customerservice@wsud.us

BILL OF SALE AND CONVEYANCE

Project Name: Payseno Apartments Phase 2

The Developer, namely, Dave Burk, for and in consideration of the mutual promises contained in the Contract, hereby grants, bargains, sells, conveys, delivers, and warrants to West Sound Utility District, the following described personal property and real property located in Kitsap County, Washington, to wit:

1. (Itemized description of Developer Improvements to be conveyed):

1 x 8" gate valve, 322 LF 8" DI pipe, 1 x 8"x8" tee, 1 x 8"x4" tee, 1 x 8" 90 deg. elbow,
1 x 4" gate valve, 2 x 8"x6" reducer, 19 LF 6" DI pipe, 2 x fire hydrant assembly,
3 x 2" water meter, 125 LF 2" water service line

2. Legal description and tax parcel numbers of all real property and easements to be conveyed:

utility easement on 312402-2-022-2009
see below

Together with any easements or other existing interests in real property incident thereto and necessary for the ownership, operation, and maintenance of the Developer Improvement.

The Developer covenants and warrants to the District, its successors, and assigns, that the Developer is the owner of the said real and personal property and has good right and authority to sell the same, and that it will and does hereby warrant and agree to defend the sale thereof to the District, its successors, and its assigns against all and every person and/or entity claiming the same, whether said claim is with or without merit.

The Developer further warrants the Developer Improvement is fit for purposes intended, i.e., for use as a water collection and conveyance system or wastewater distribution system, and that the same has been constructed in accordance with this Contract.

The Developer further covenants, warrants, and agrees to repair, correct and bear the cost of any defect concerning any work or material associated with construction of the Developer Improvement which may arise for a two year period from the District's date of acceptance of this Bill of Sale, and to hold the District harmless from any and all costs arising in connection therewith or any and all liability of every kind and nature arising therefrom. When corrections of defects occurring within the warranty period are made, the Developer shall further warrant corrected work for two years after acceptance of the corrected work by the District.

Dated this 9 of May, 2023.

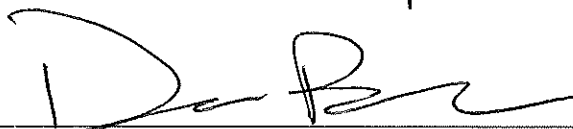
Developer by: 

Print Name: Dave Burk

State Title: owner

Its duly authorized representative for entry into this Exhibit

Address 1665 Payson Lane SE, Port Orchard, WA 98367

Contact telephone numbers: 360-340-6624

Accepted by WEST SOUND UTILITY DISTRICT on this _____ day of _____, 20____
pursuant to the District Resolution hereinafter set forth.

Resolution No. _____ WEST SOUND UTILITY DISTRICT

By _____
General Manager